

# Footing Design

# *Types of Footing*

***Wall footings*** are used to support structural walls that carry loads for other floors or to support nonstructural walls.

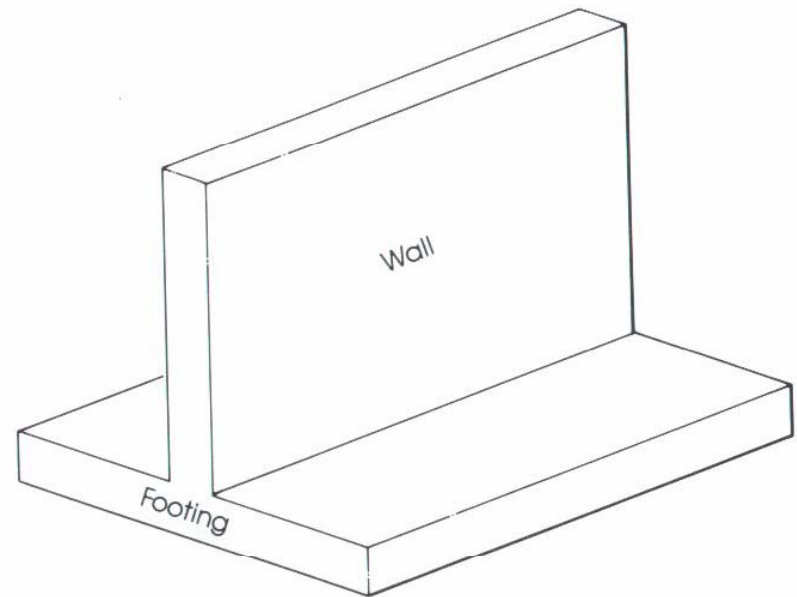

Wall footing.

# Types of Footing

***Isolated or single footings*** are used to support single columns. This is one of the most economical types of footings and is used when columns are spaced at relatively long distances.

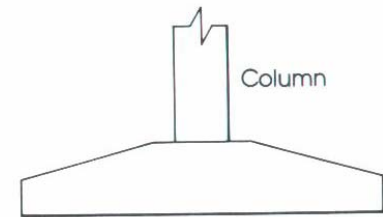
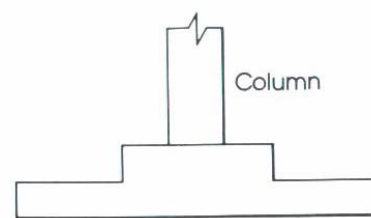
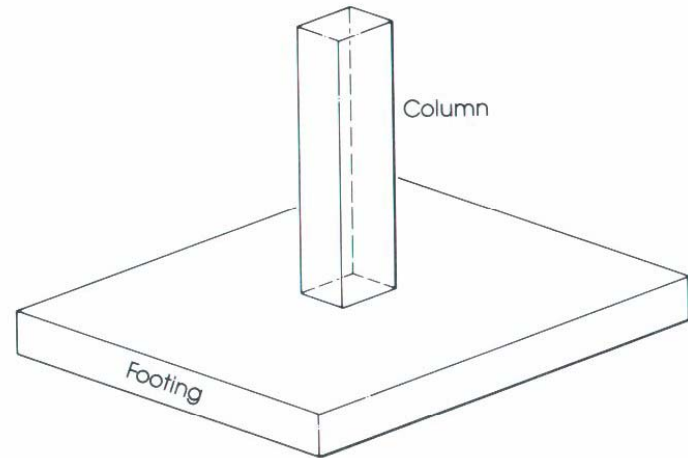

# Types of Footing

**Combined footings** usually support two columns, or three columns not in a row. Combined footings are used when two columns are so close that single footings cannot be used or when one column is located at or near a property line.

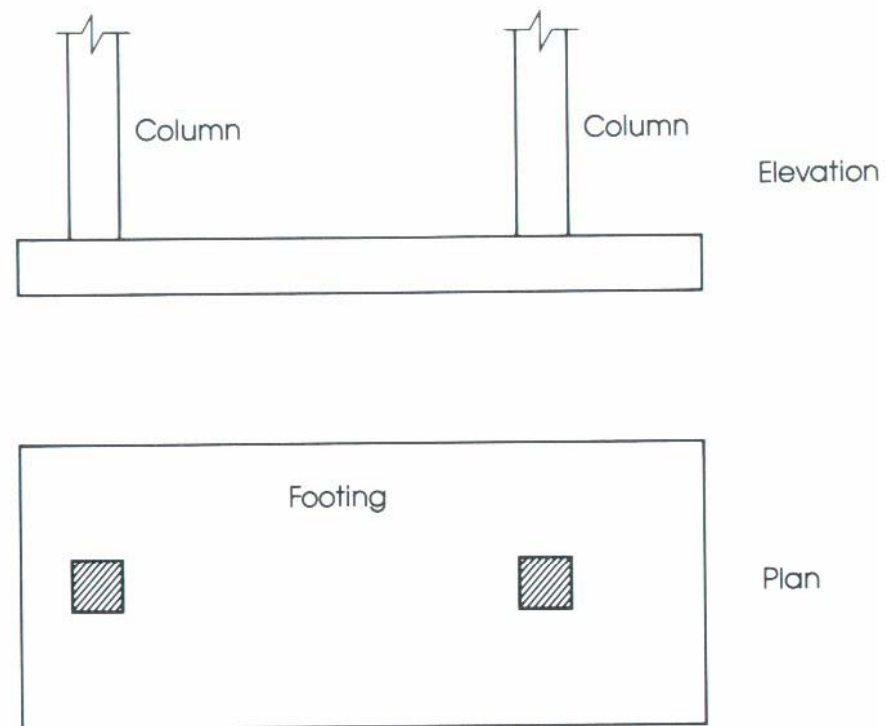

# *Types of Footing*

*Cantilever or strap footings* consist of two single footings connected with a beam or a strap and support two single columns. This type replaces a combined footing and is more economical.

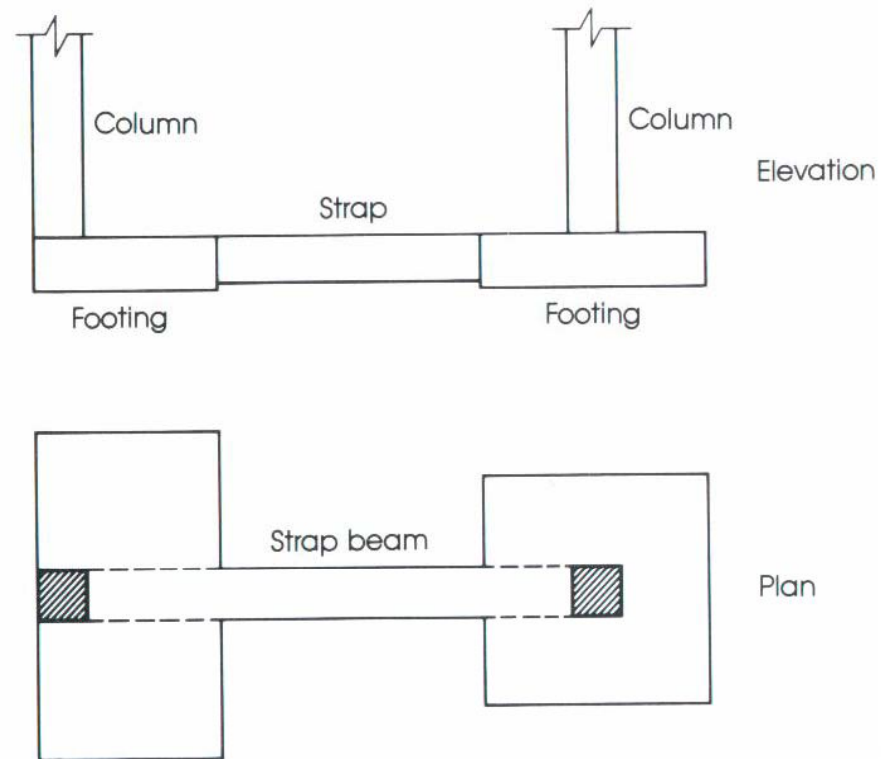

# Types of Footing

***Continuous footings*** support a row of three or more columns. They have limited width and continue under all columns.

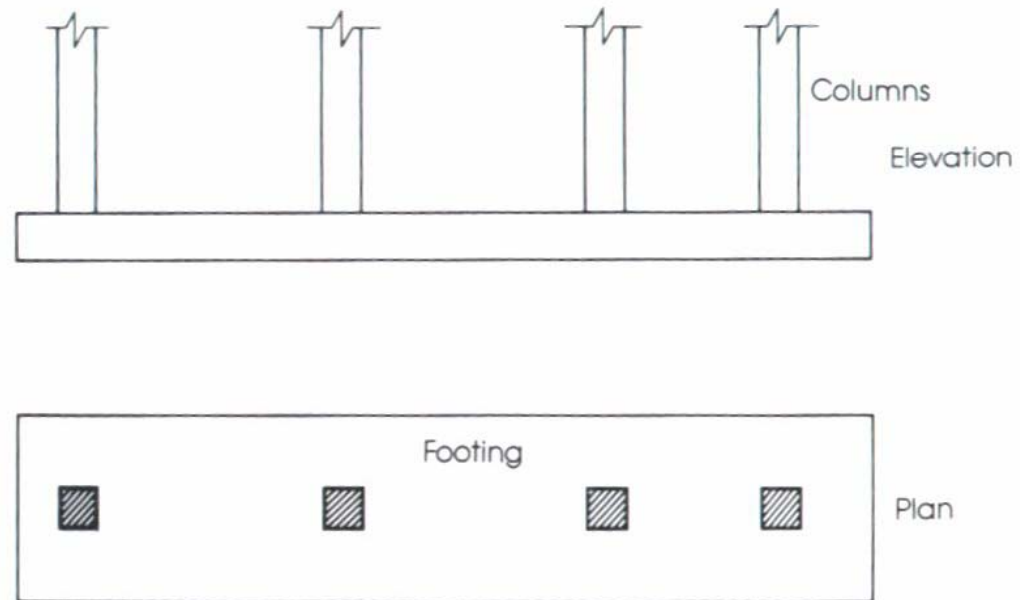

# Types of Footing

***Rafted or mat foundation*** consists of one footing usually placed under the entire building area. They are used, when soil bearing capacity is low, column loads are heavy single footings cannot be used, piles are not used and differential settlement must be reduced.

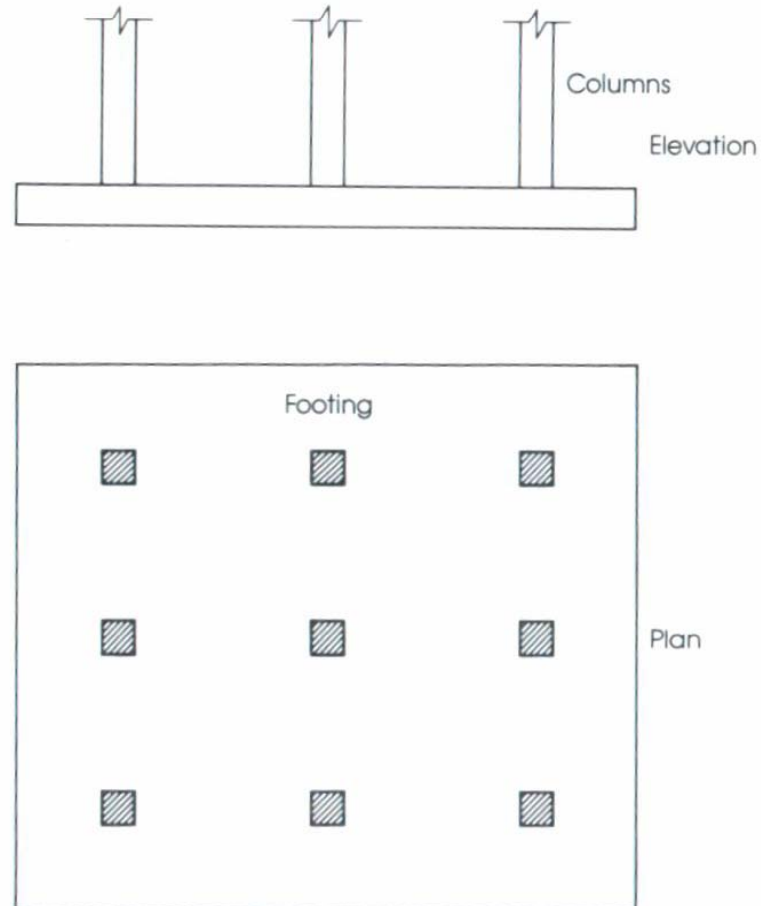

# Types of Footing

**Pile caps** are thick slabs used to tie a group of piles together to support and transmit column loads to the piles.

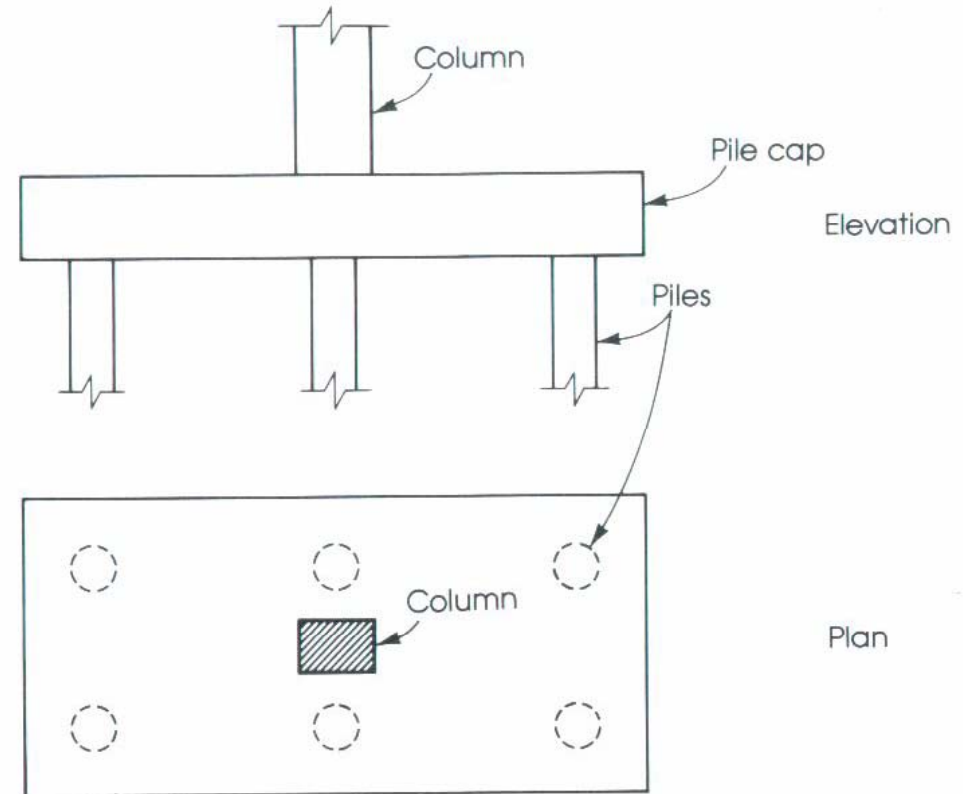



# *Distribution of Soil Pressure*

*When the column load  $P$  is applied on the centroid of the footing, a uniform pressure is assumed to develop on the soil surface below the footing area. However the actual distribution of the soil is not uniform, but depends on many factors especially the composition of the soil and degree of flexibility of the footing.*

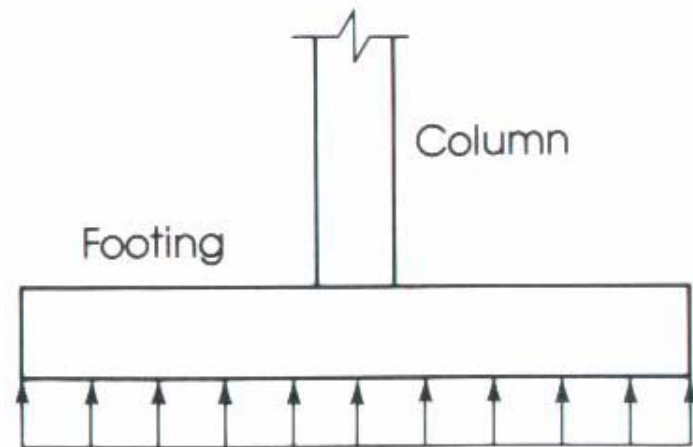

# *Distribution of Soil Pressure*

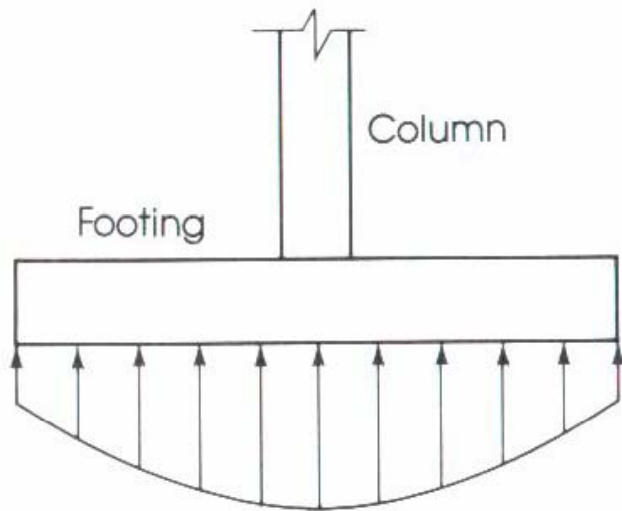

*Soil pressure distribution in cohesionless soil.*

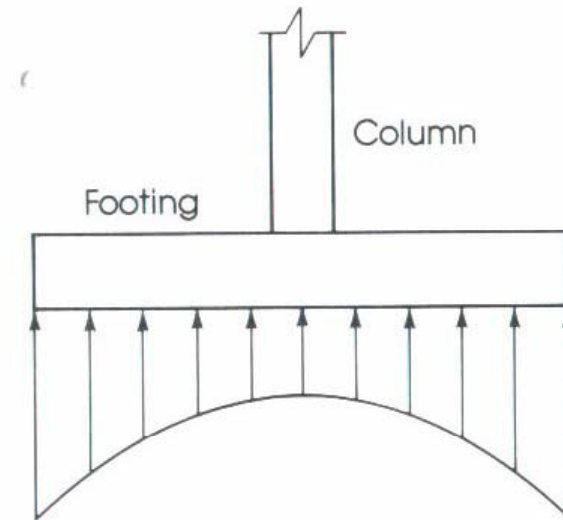

*Soil pressure distribution in cohesive soil.*

# Eccentrically loaded footings

Footings are frequently designed for both axial load and moment. Moment may be caused by lateral forces due to wind or earthquake, by lateral soil pressures or by thrust at the base of a column.

The pressure distribution on the base of footing that support combined concentric load  $P$  (at the centroid of footing) and moment  $M$  is given by the following equation

$$p = \frac{P}{A} \pm \frac{Mc}{I}$$

where  $c$  = the distance from the centroid perpendicular to the axis of bending moment.

$I$  = the moment of inertia of footing around the axis of bending.

In the footing, minimum pressure will be zero when the compressive pressure as a result of direct load equals tensile stresses produced from moment,

$$\frac{P}{A} = \frac{Mc}{I} \Rightarrow e = \frac{M}{P} = \frac{I}{Ac} = \frac{BL^2/12}{(BL)(L/2)} = \frac{L}{6}$$

In case that eccentricity is small such as

$$e < \frac{L}{6}$$

then pressure distribution shape will be a trapezoidal

In case that eccentricity is large such as

$$e > \frac{L}{6}$$

then a triangular stress distribution will develop over a portion of the footing

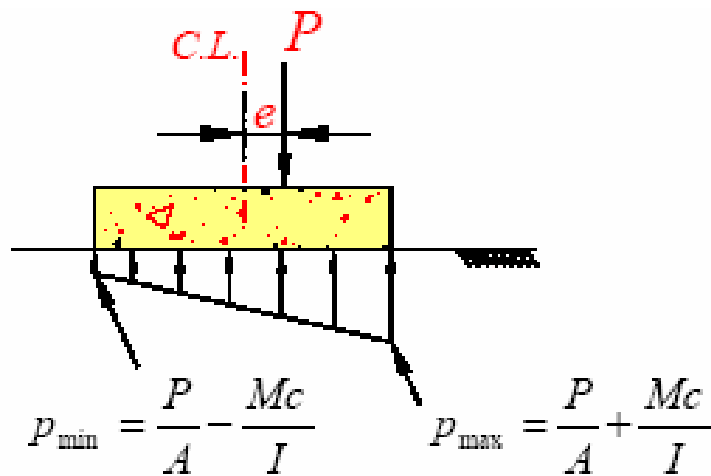
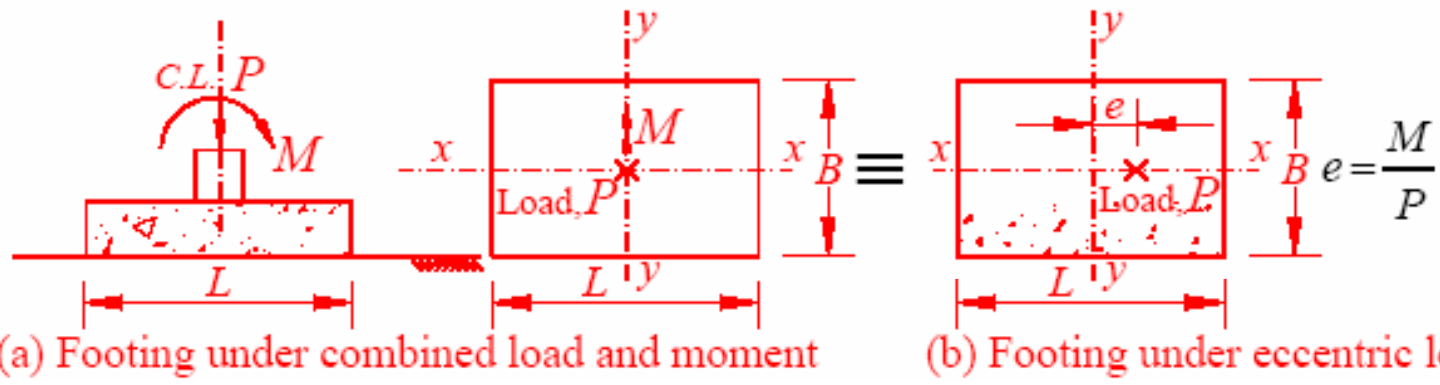

(c) Small eccentricity of load,  $e < h/6$

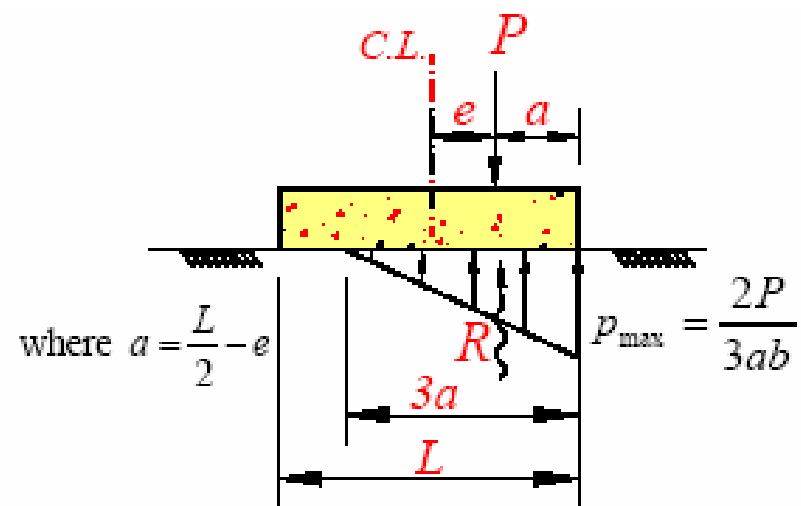

(d) Large eccentricity of load,  $e > h/6$

Soil pressure under an eccentrically loaded rectangular footing

# *Eccentrically loaded footings Example*

*Isolated Footing*

*D.L = 900 kN*

*L.L = 450 kN*

*M<sub>s</sub> = 150 kN.m*

*M<sub>u</sub> = 200 kN.m*

*q<sub>all</sub> = 200 kpa*

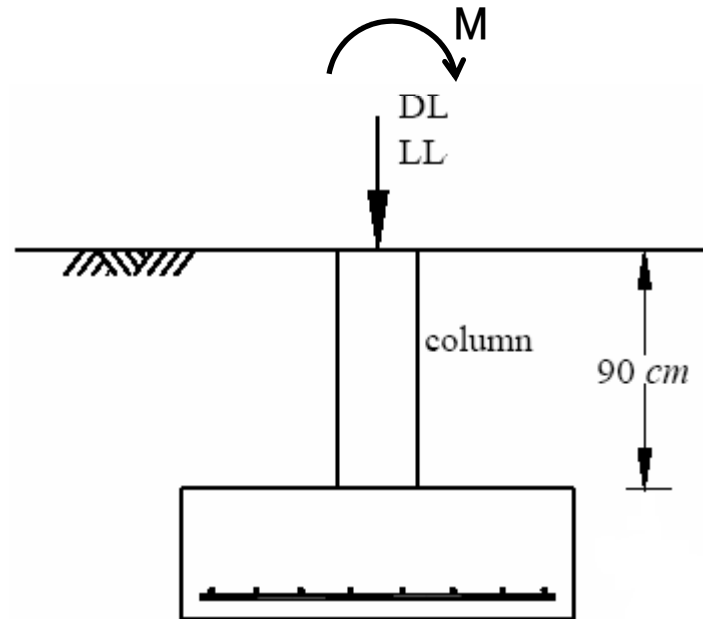

## Area required approximated

$$q_{all(net)} = 20t / m^2 = 200kPa$$

$$A_g = \frac{P_s}{q_{all(net)}} = \frac{(900 + 450) \times 10^3}{200 \times 10^3} = 6.7$$

use  $(3.5m \times 2.5m)$

$$A = 8.75m^2$$

$$I = \frac{3.5^3 \times 2.5}{12} = 8.9m^4$$

Check stress

$$e = \frac{M}{P} = \frac{150}{1350} = 0.111 < \frac{L}{6} = \frac{3.5}{6} = 0.583$$

$$\frac{P_s}{A} + \frac{M_s C}{I} = \frac{1350}{8.75} + \frac{150 \times \frac{3.5}{2}}{8.9} = 183.7kPa$$

$$\frac{P_s}{A} - \frac{M_s C}{I} = \frac{1350}{8.75} - \frac{150 \times \frac{3.5}{2}}{8.9} = 124.7kPa$$

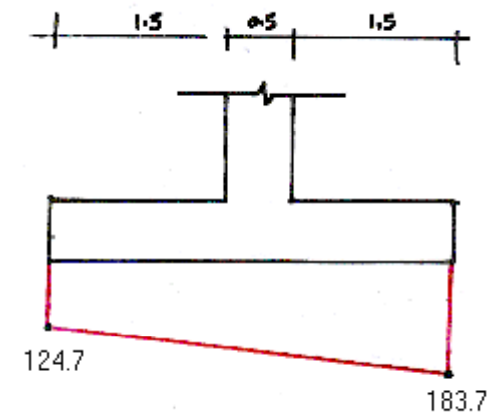
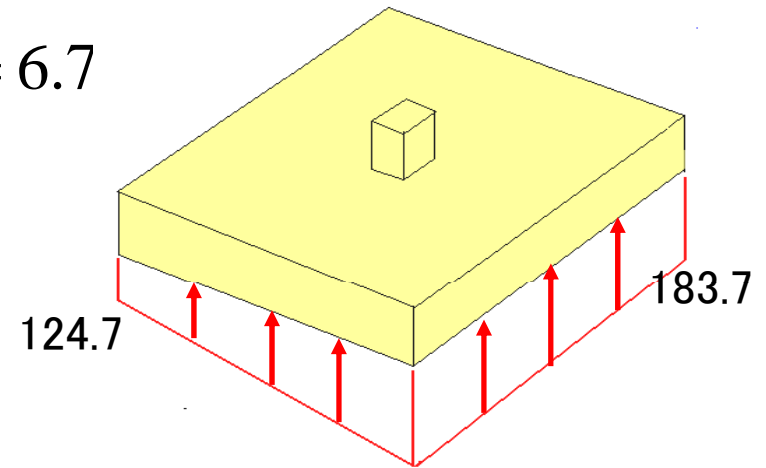

## Ultimate pressure under footing

$$P_u = 1.2(900) + 1.6(450) = 1800 \text{ kN}$$

$$M_u = 200 \text{ kN.m}$$

$$\frac{P_u}{A} + \frac{M_u C}{I} = \frac{1800}{8.75} + \frac{200 \times \frac{3.5}{2}}{8.9} \approx 245 \text{ kPa}$$

$$\frac{P_u}{A} - \frac{M_u C}{I} = \frac{1800}{8.75} - \frac{200 \times \frac{3.5}{2}}{8.9} \approx 166 \text{ kPa}$$

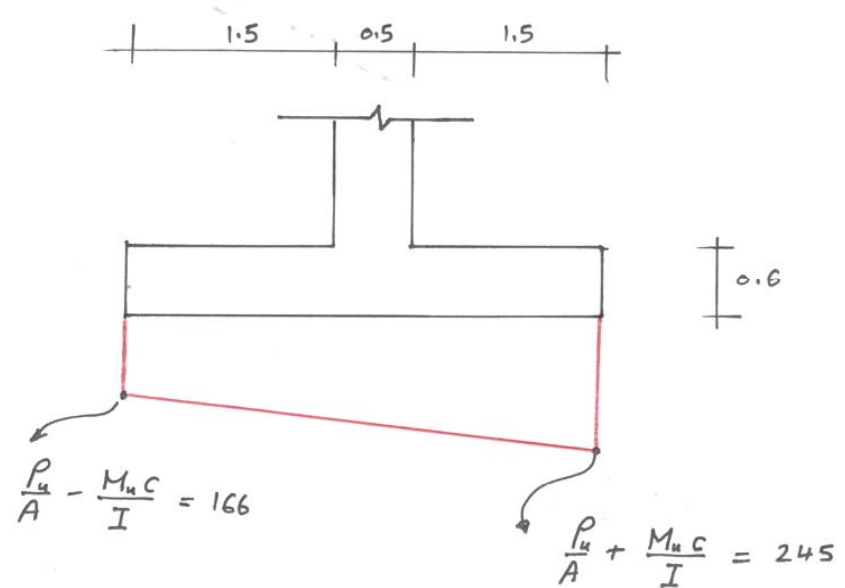
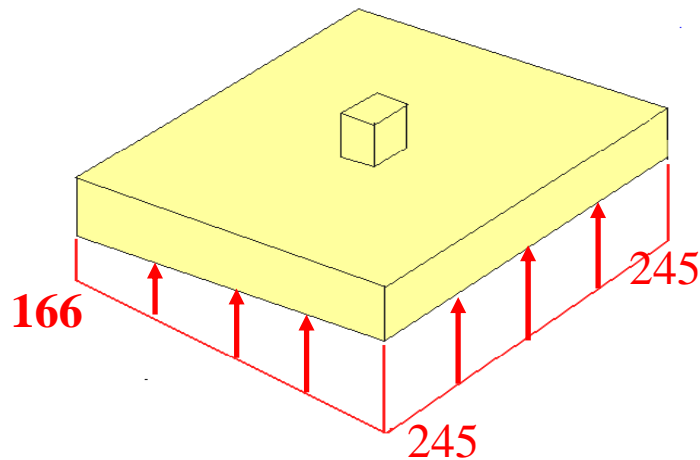



## Check Punching Shear

$$b_o = 4[(530 + 400)] = 3720 \text{ cm}$$

For square column the suitable  $\phi V_c$  equation is :

$$\phi V_c = \phi \frac{\sqrt{f_c'}}{3} b_o d = 0.75 \times \frac{\sqrt{25}}{3} \times 530 \times 3720 / 1000 = 2464.5 \text{ kN}$$

$$V_U \approx \frac{(166+245+166+245)}{4} (3.5 \times 2.5) = 1798 \text{ kN}$$

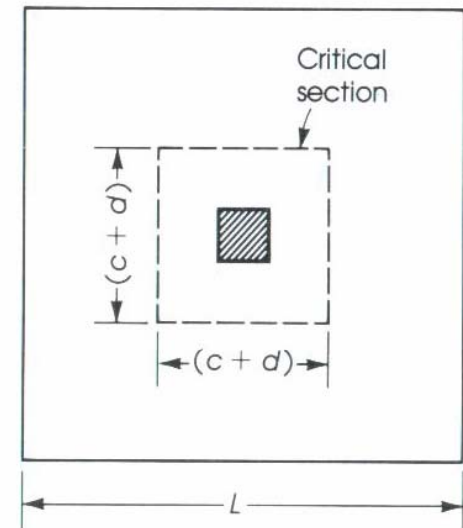

## Check Beam Shear

$$\phi V_C = 0.75 \times \frac{\sqrt{25}}{6} \times 530 \times 2500 / 1000 = 828.13 \text{ kN}$$

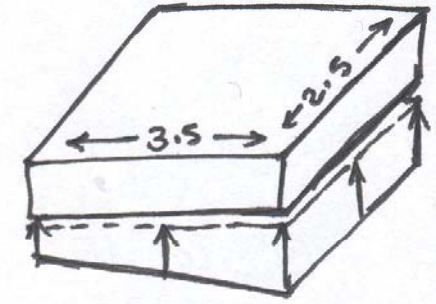

$V_U$  at  $\underline{\underline{d}}$  from column face  $\Rightarrow$

$$V_U = \left( \frac{223 + 245}{2} \right) * (1.5 - 0.53) * 2.5$$

$$= 567.5 \text{ kN}$$

$$V_U < \phi V_C$$

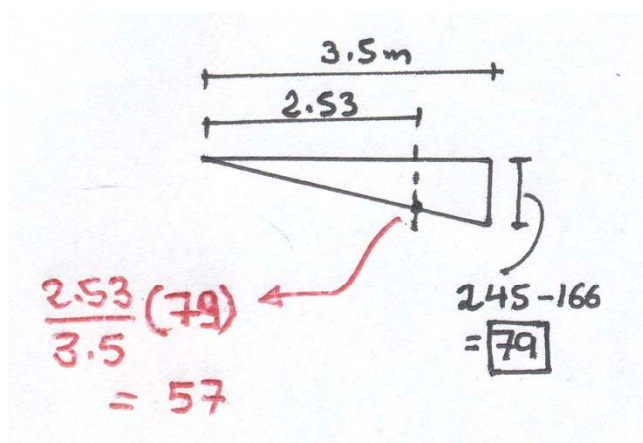
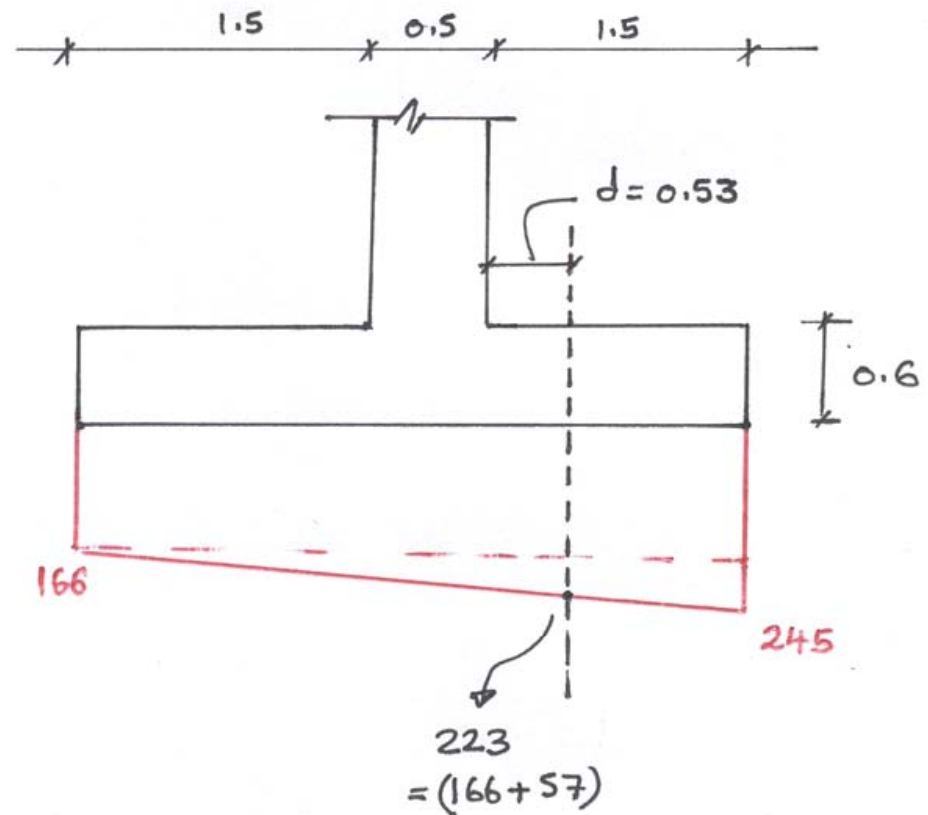

## Bending moment design

### Long direction

$M_U$  at d from column face  $\Rightarrow$

$$P_1 = 211(1.5)(2.5) = 791.25kN$$

$$P_2 = \frac{1}{2}(245 - 211)(1.5)(2.5) = 63.75kN$$

$$M_U = P_1(0.75) + P_2(1) = 791.25(0.75) + 63.75(1) = 657.2kN.m$$

$$b = 2500, d = 530mm$$

$$\rho = 0.85 * \frac{25}{420} \left[ 1 - \sqrt{1 - \frac{2 \times 10^6 * 657.2}{0.9(0.85)25 * 530^2 * 2500}} \right] = 0.00254$$

$$A_s = 0.00254 \times 530 \times 1000 = 1346mm^2 \approx 13.5cm^2 \quad \text{use } 7\phi 16/m \text{ long direction}$$

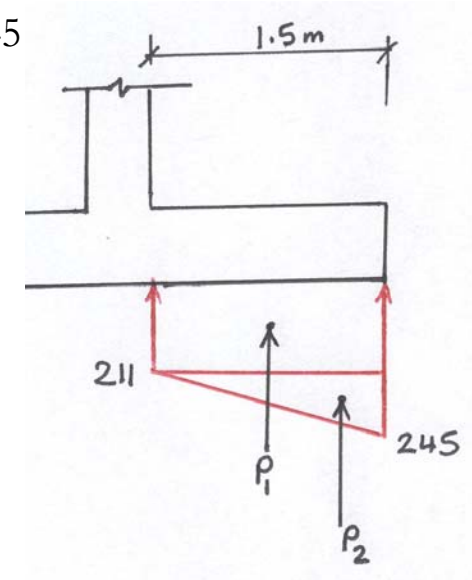
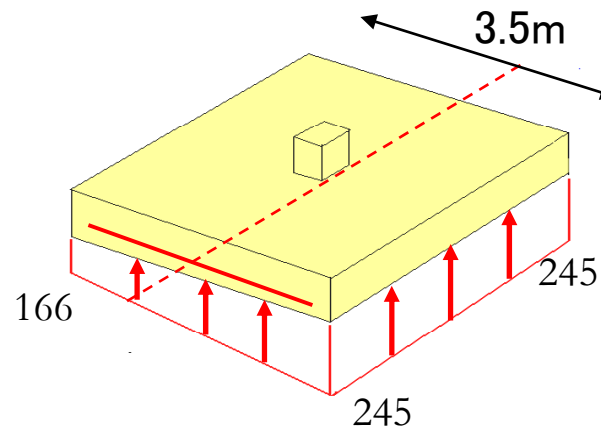

## Bending moment design

### Short direction

$M_U$  at  $d$  from column face  $\Rightarrow$

$$M_U = \left( \frac{(245 + 166)}{2} (1 \times 3.5) \right) 0.5 = 719.25 \text{ kN.m}$$

$b = 3500$ ,  $d = 530 \text{ mm}$

$$\rho = 0.85 * \frac{25}{420} \left[ 1 - \sqrt{1 - \frac{2 \times 10^6 * 719.25}{0.9(0.85)25 * 530^2 * 3500}} \right] = 0.002$$

$$A_s = 0.002 \times 530 \times 1000 = 1060 \text{ mm}^2 \approx 10.1 \text{ cm}^2 \quad \text{short direction}$$

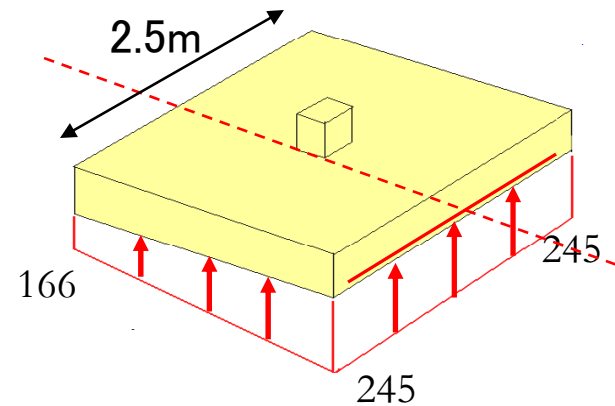

$$\text{Central band ratio} = \frac{2}{\beta + 1}$$

$$\beta = \frac{\text{Long side dimension of footing}}{\text{Short side dimension of the footing}}$$

$$\beta = \frac{3.5}{2.5} = 1.4$$

$$\frac{2}{\beta + 1} = \frac{2}{2.4} = 0.83$$

$$\text{Central band of short direction} = 0.83 \text{ } A_s = 0.83 (10.1) = 8.6 \text{ cm}^2$$

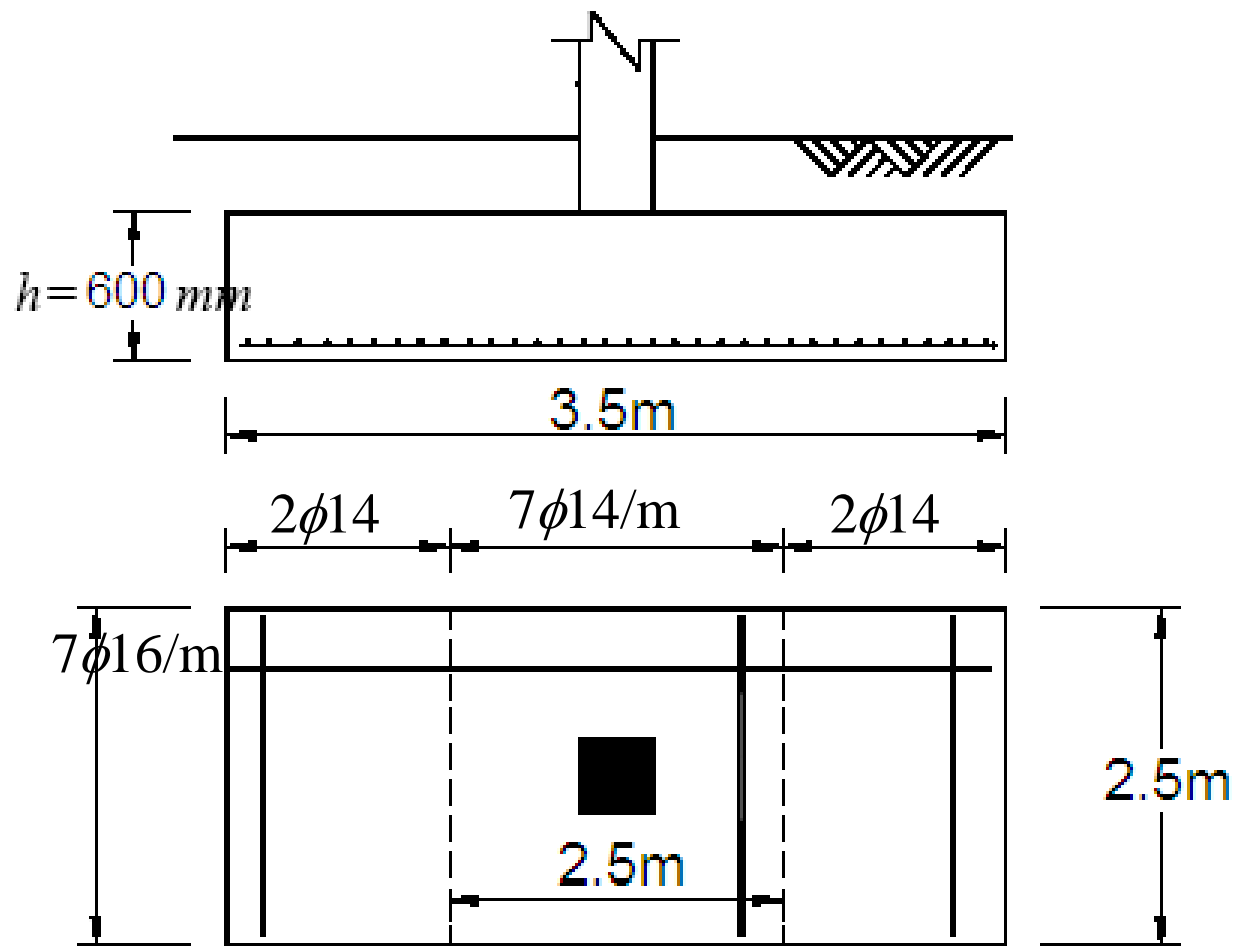

# Footing Design

## Part II

### *Combined footing*

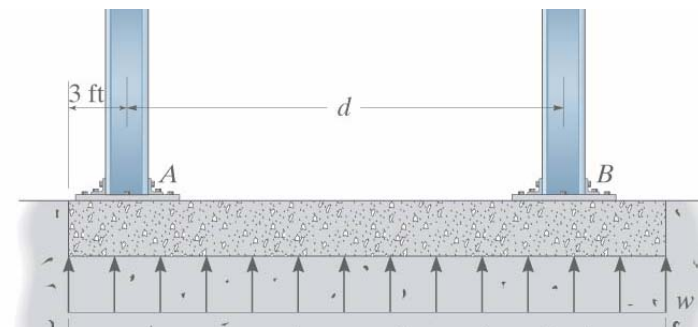

# Example 1

Design a combined footing As shown

$$q_{all(net)} = 20t / m^2 = 200kPa \quad f'_c = 25 N/mm^2 \quad f_y = 420 N/mm^2$$

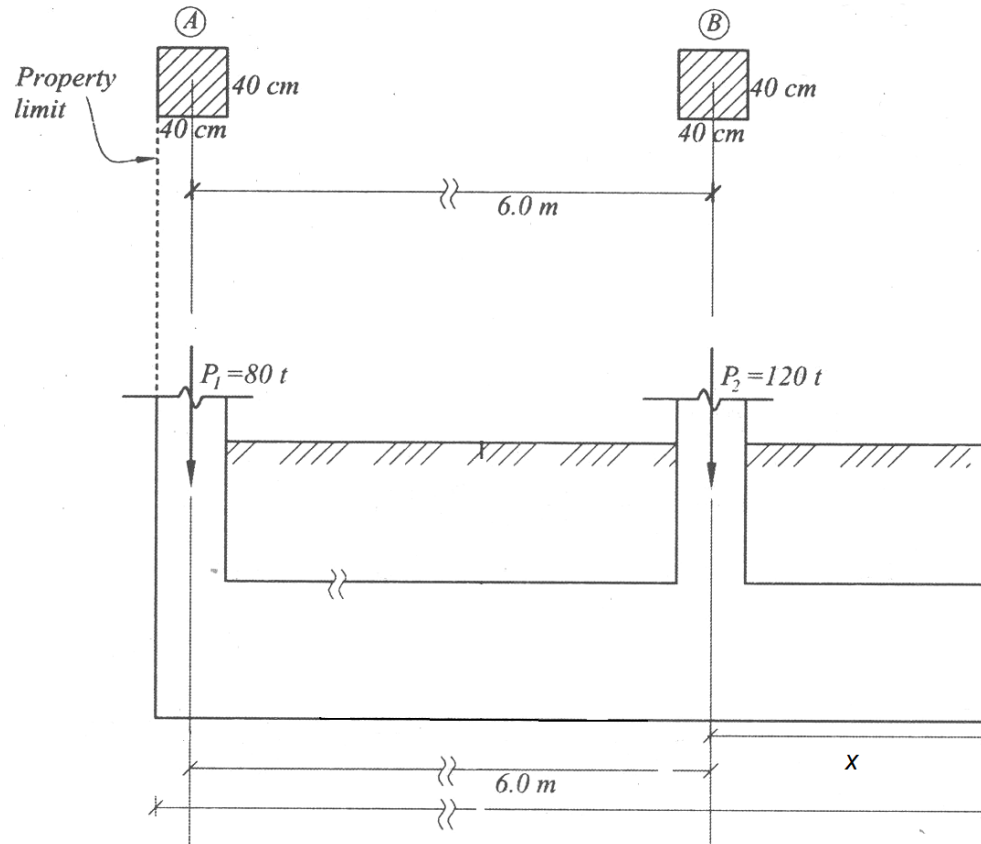



## Dimension calculation

The base dimension to get uniform distributed load

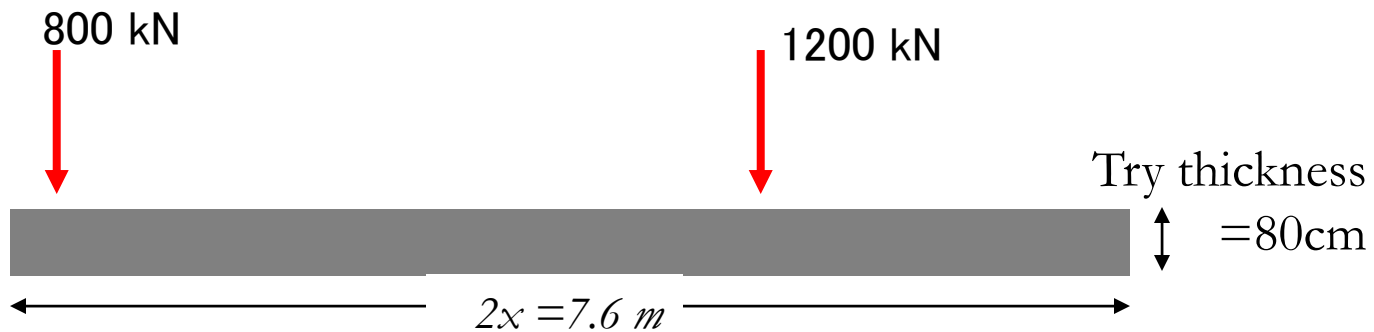
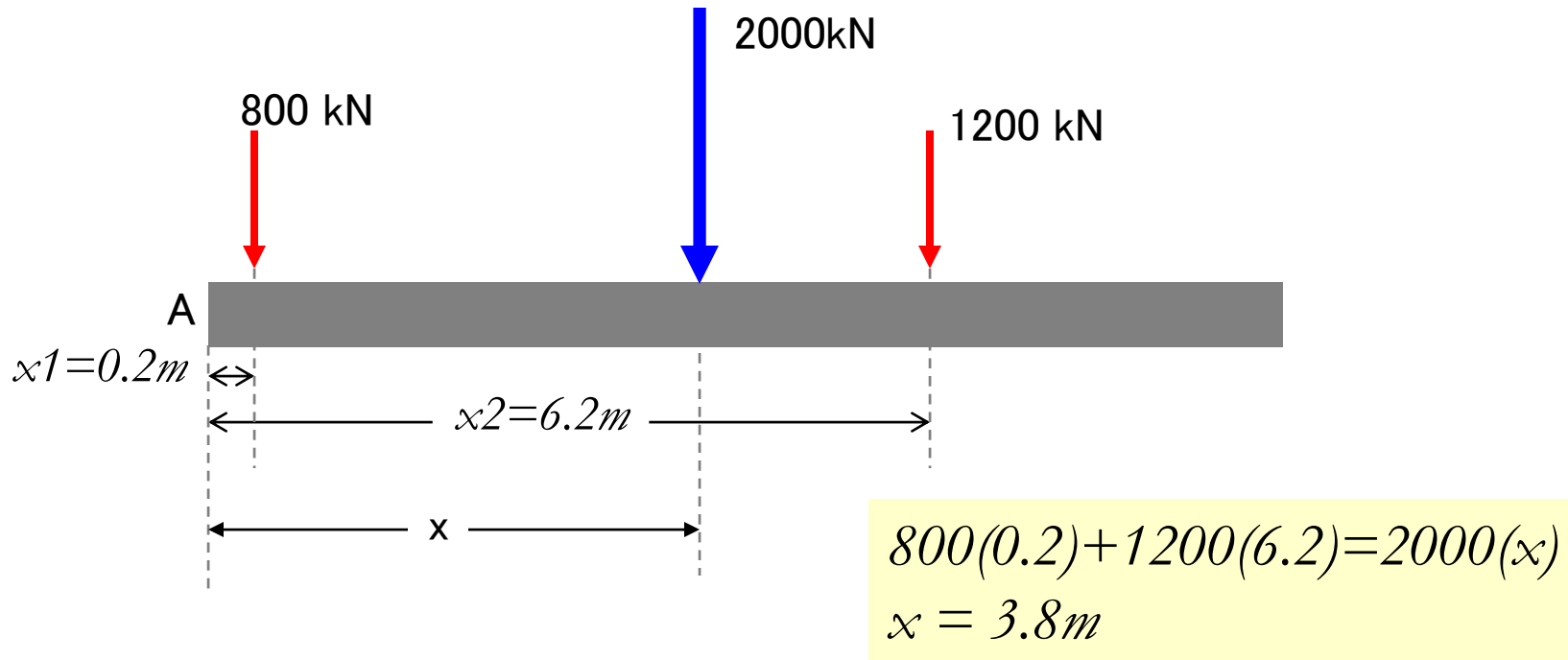

## Area required

$$q_{all(net)} = 20t / m^2 = 200kPa,$$

$$P_u = 1.3(P_s) = 1.3(2000) = 2600kN$$

$$A_g = \frac{P_s}{q_{all(net)}} = \frac{2000 \times 10^3}{200 \times 10^3} = 10m^2 \approx 7.6 * 1.8$$

$$q_u = \frac{P_u}{A} = \frac{(2600) \times 10^3}{7.6 * 1.8} = 190 \times 10^3 Pa = 190kPa$$

## Check for punching Shear

$d = 730 \text{ mm}$

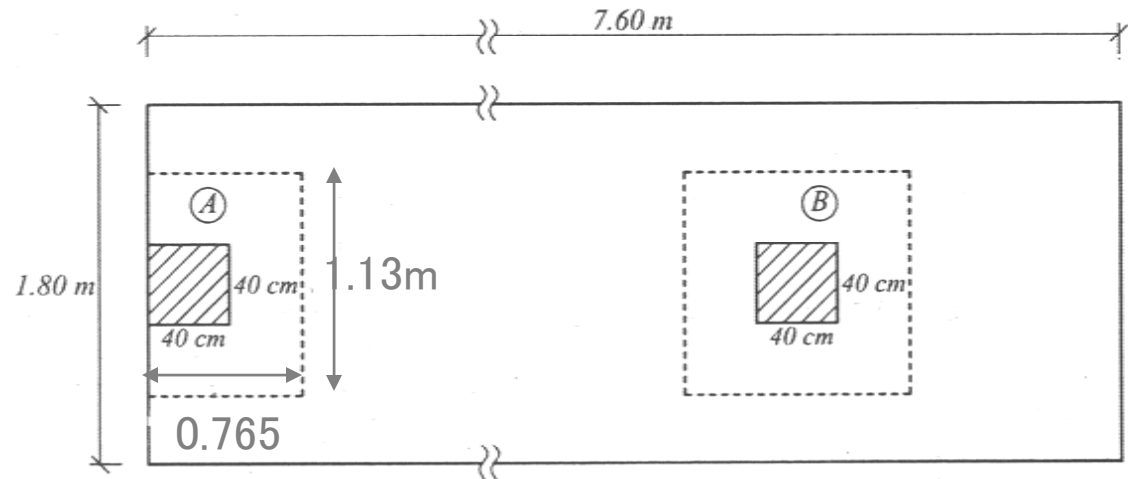

A

$$b_o = 2(765) + 1130 = 2260 \text{ mm}$$

$$\phi V_c = \phi \frac{\sqrt{f'_c}}{3} b_o d = 0.75 \times \frac{\sqrt{25}}{3} \times 730 \times 2260 / 1000 = 2062.3 \text{ kN}$$

$$\phi V_c = \phi \left( 2 + \frac{\alpha_s d}{b} \right) \frac{\sqrt{f'_c}}{12} b_o d = 0.75 \left( 2 + \frac{30 \times 730}{2260} \right) \times \frac{\sqrt{25}}{12} \times 730 \times 2260 / 1000 = 6027 \text{ kN}$$

$$V_U = 800(1.3) - 1.13 \times 0.765 \times 190 = 875.8 \text{ kN} < \phi V_c \quad \text{oK}$$

## B

$$b_o = 4[(730 + 400)] = 4520\text{mm}$$

$$\phi V_c = \phi \frac{\sqrt{f_c'}}{3} b_o d = 0.75 \times \frac{\sqrt{25}}{3} \times 730 \times 4520 / 1000 = 4124.4\text{kN}$$

$$\phi V_c = \phi \left( 2 + \frac{\alpha_s d}{b} \right) \frac{\sqrt{f_c'}}{12} b_o d = 0.75 \left( 2 + \frac{40 \times 730}{4520} \right) \times \frac{\sqrt{25}}{12} \times 730 \times 4520 / 1000 = 13322.5\text{kN}$$

$$V_U = 1200(1.3) - 1.13 * 1.13 * 190 = 1317.4\text{kN} < \phi V_c \quad \text{oK}$$

## Draw S.F.D & B.M.D

Stress under footing  
 $= 190 * 1.8 = 342 \text{ kN/m}$

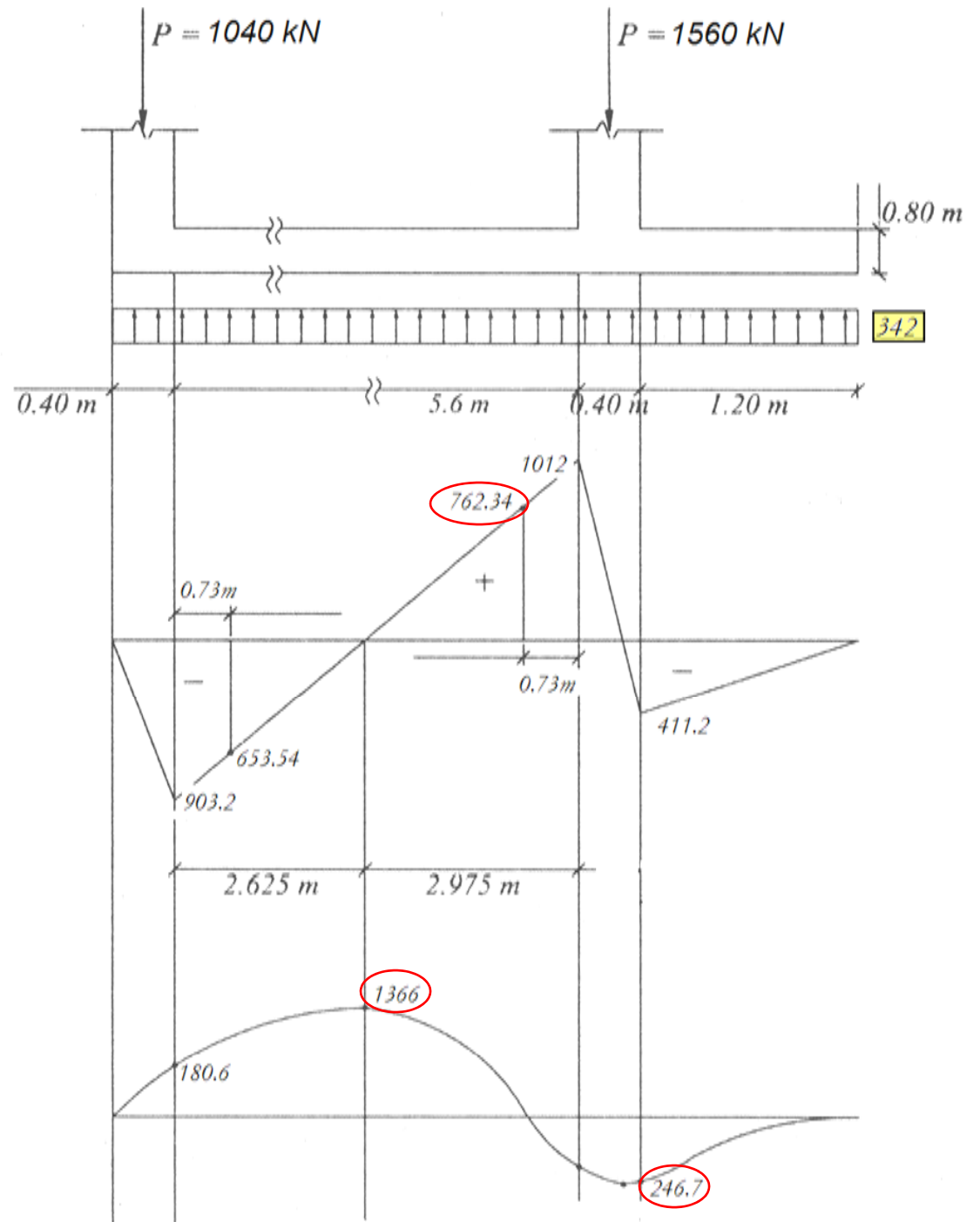

## Check for beam shear

$$b = 1800\text{mm}, d = 730\text{mm}$$

$$\phi V_c = 0.75 \times \frac{\sqrt{25}}{6} \times 730 \times 1800 / 1000 = 821.25\text{kN}$$

$$\text{Max.} \rightarrow V_U \text{ at } \underline{\underline{d}} \text{ from column face} = 762.34\text{kN}$$

$$V_U < \phi V_c$$

## Bending moment Long direction

$$-ve M = 1366kN.m$$

$$b = 1800mm, d = 730mm$$

$$\rho = 0.85 * \frac{25}{420} \left[ 1 - \sqrt{1 - \frac{2 \times 10^6 * 1366}{0.9(0.85)25 * 730^2 * 1800}} \right] = 0.0039$$

$$A_s = 0.0039 \times 730 \times 1000 = 2847mm^2 = 28.5cm^2 \quad use 9\phi 20 / m \quad \text{Top}$$

$$+ve M = 246.7kN.m$$

$$b = 1800mm, d = 730mm$$

$$\rho = 0.85 * \frac{25}{420} \left[ 1 - \sqrt{1 - \frac{2 \times 10^6 * 246.7}{0.9(0.85)25 * 730^2 * 1800}} \right] = 0.0007 < \rho_{min}$$

$$A_{s_{min}} = 0.0018 \times 800 \times 1000 = 1440mm^2 = 14.4cm^2 \quad use 7\phi 16 / m \quad \text{Bottom}$$

## Bending moment Short direction

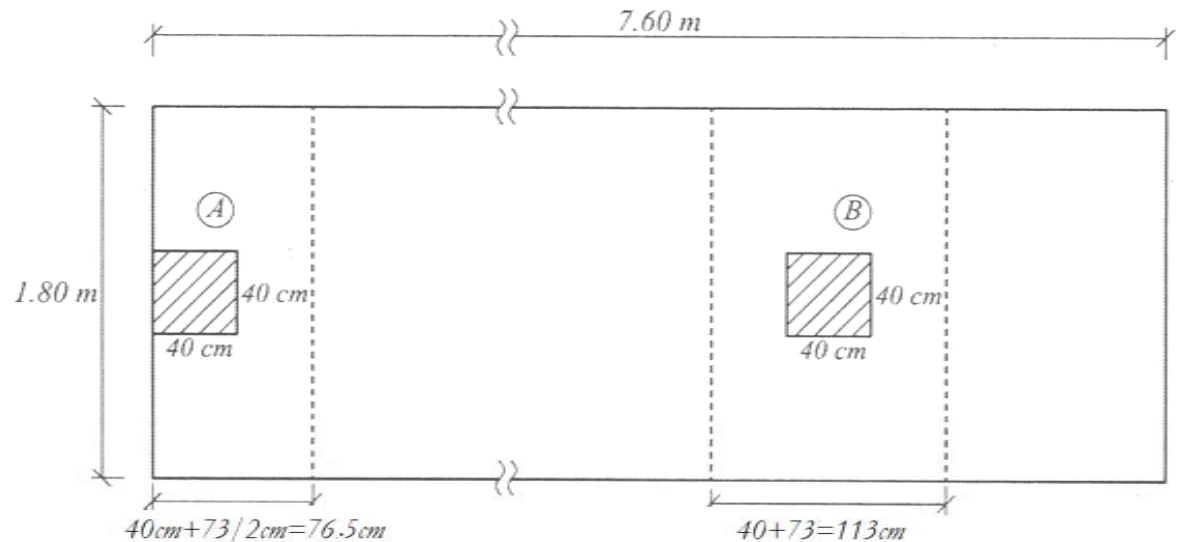

Under Column A

$$M = \frac{1040}{(1.8 * 0.765)} \times \frac{0.765}{2} \left( \frac{1.8 - 0.4}{2} \right)^2 = 141.6$$

$$b = 765 \text{ mm}, d = 730 \text{ mm}$$

$$\rho = 0.85 * \frac{25}{420} \left[ 1 - \sqrt{1 - \frac{2 \times 10^6 * 141.6}{0.9(0.85)25 * 730^2 * 765}} \right] < \rho_{\min}$$

$$A_{S_{\min}} = 0.0018 \times 800 \times 765 = 1101.6 \text{ mm}^2 = 11 \text{ cm}^2 \quad \text{use } 7\phi 14 / m$$



### Under Column B

$$M = \frac{1560}{(1.8 * 1.13)} \times \frac{1.13}{2} \left( \frac{1.8 - 0.4}{2} \right)^2 = 212.33$$

$$b = 1130mm, d = 730mm$$

$$\rho = 0.85 * \frac{25}{420} \left[ 1 - \sqrt{1 - \frac{2 \times 10^6 * 212.33}{0.9(0.85)25 * 730^2 * 1130}} \right] < \rho_{\min}$$

$$A_{S\min} = 0.0018 \times 800 \times 765 = 1101.6mm^2 = 11cm^2 \quad \text{use } 7\phi 14 / m$$

### Shrinkage Reinforcement in short direction

$$A_{S\min} = 0.0018 \times 800 \times 765 = 1101.6mm^2 = 11cm^2 \quad \text{use } 7\phi 14 / m$$

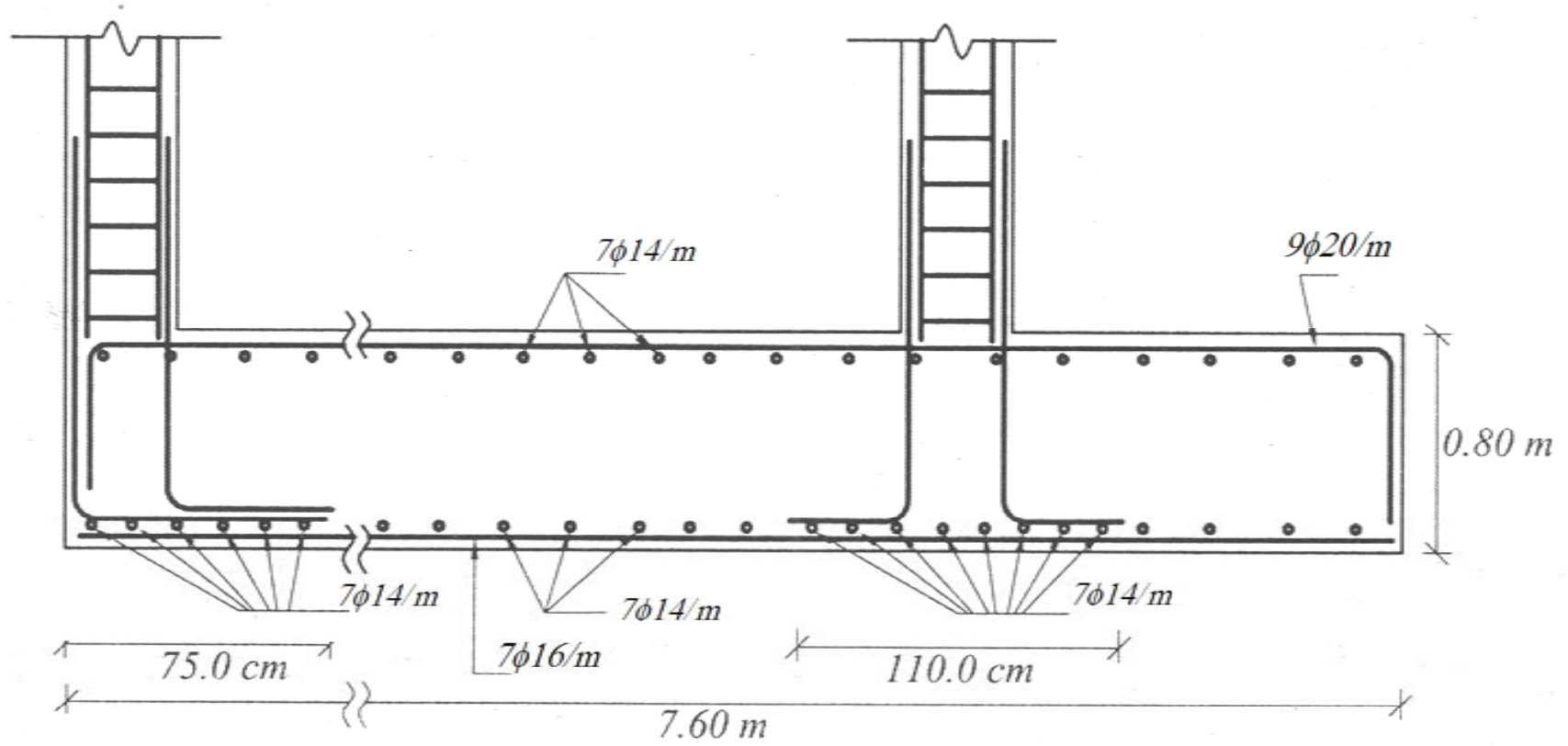

# Footing Design

## Part III

*Combined footing, strip footing, & Mat foundation*

# Example 2

Design a combined footing As shown

$$q_{all(net)} = 18 t / m^2 = 180 kPa \quad f'_c = 25 N / mm^2 \quad f_y = 420 N / mm^2$$

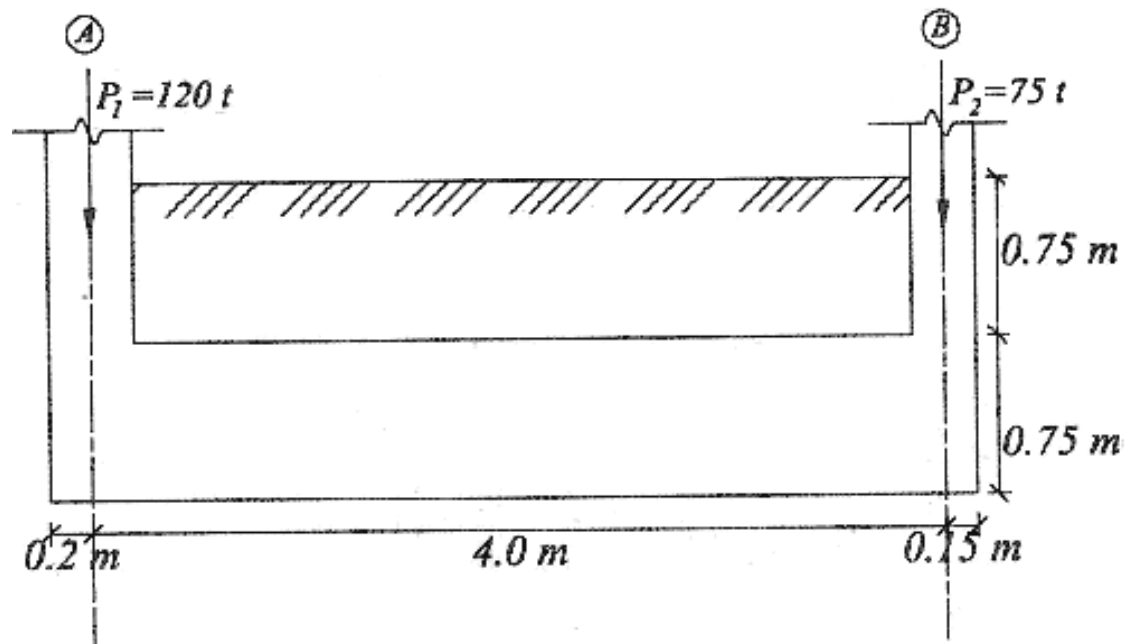

## Dimension calculation

The base dimension to get uniform distributed load

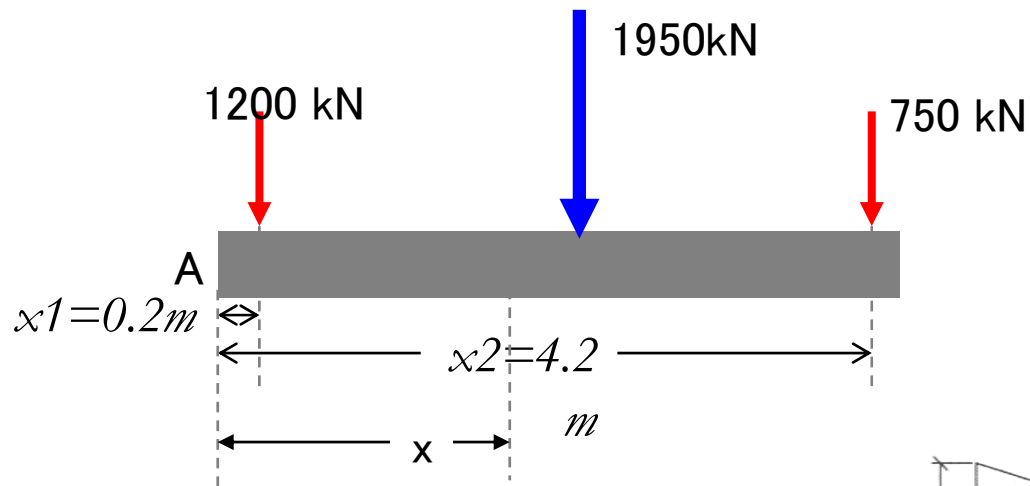

$$750(4.2) + 1200(0.2) = 1950 (x)$$
$$x = 1.75\text{ m}$$

$$x = \left( \frac{B_1 + 2B_2}{B_1 + B_2} \right) \frac{L}{3}$$

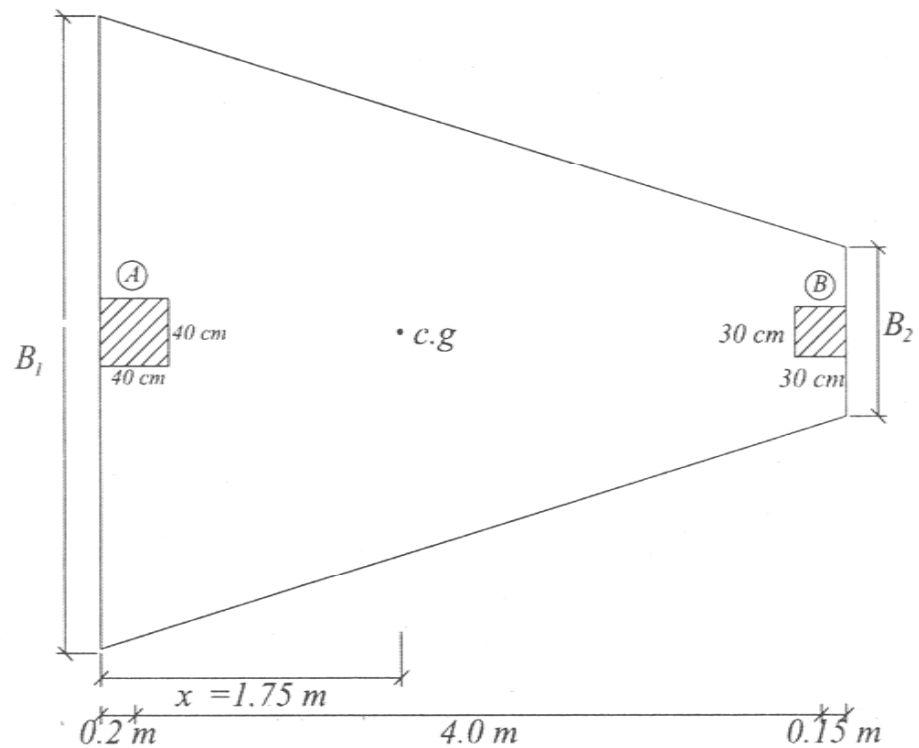

## Area required

$$q_{all(net)} = 20t / m^2 = 200kPa,$$

$$A_g = \frac{P_s}{q_{all(net)}} = \frac{1950 \times 10^3}{180 \times 10^3} = 10.8m^2$$

$$\rightarrow \left( \frac{B_1 + B_2}{2} \right) L = 10.8$$

$$\left( \frac{B_1 + B_2}{2} \right) 4.35 = 10.8$$

$$\left( \frac{B_1 + B_2}{2} \right) = 2.5$$

$$B_1 + B_2 = 5$$

$$\rightarrow x = \left( \frac{B_1 + 2B_2}{B_1 + B_2} \right) \frac{L}{3} = \left( \frac{5 + B_2}{5} \right) \frac{4.35}{3}$$

$$1.75 = 1.45 + 0.29B_2$$

$$B_2 = 1m$$

$$B_1 = 4m$$

$$q_u = \frac{P_u}{A} = \frac{1.3(1950) \times 10^3}{10.8} = 235 \times 10^3 Pa = 235kPa$$

## Check for punching Shear

$$h = 750 \text{ mm}$$

$$d = 732 \text{ mm}$$

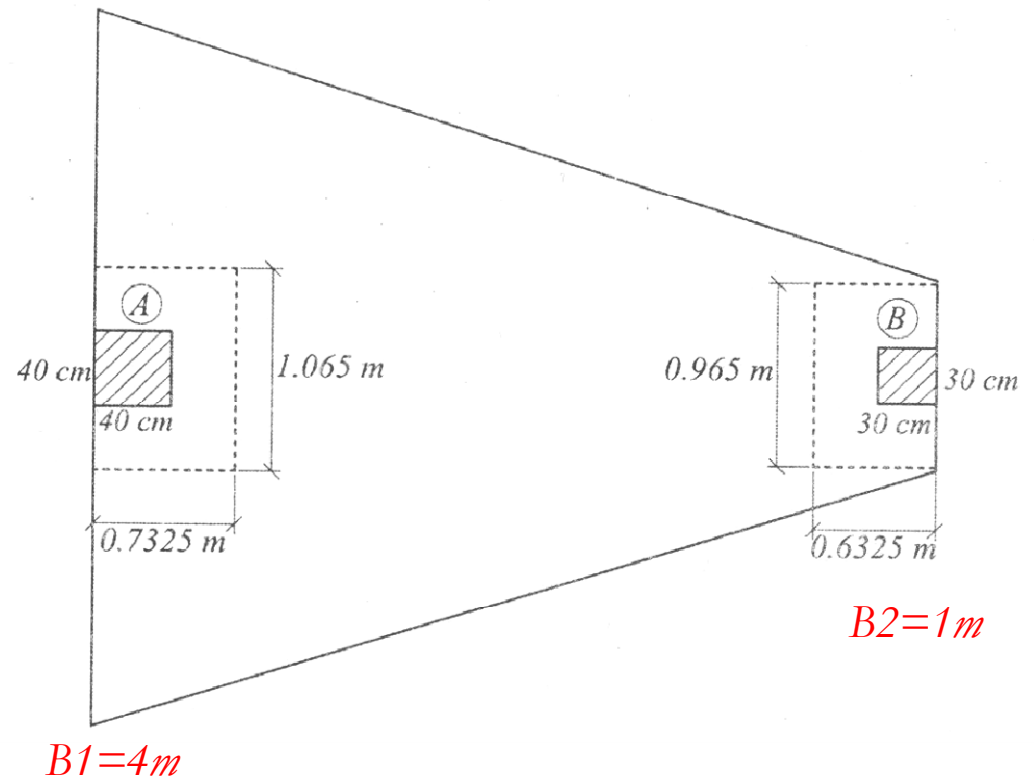

A

$$b_o = 2(732) + 1065 = 2590 \text{ mm}$$

$$\phi V_c = \phi \frac{\sqrt{f_c'}}{3} b_o d = 0.75 \times \frac{\sqrt{25}}{3} \times 665 \times 2590 / 1000 = 2160.4 \text{ kN}$$

$$\phi V_c = \phi \left( 2 + \frac{\alpha_s d}{b} \right) \frac{\sqrt{f_c'}}{12} b_o d = 0.75 \left( 2 + \frac{30 \times 665}{2590} \right) \times \frac{\sqrt{25}}{12} \times 665 \times 2590 / 1000 = 5222 \text{ kN}$$

$$V_U = 1200(1.3) - 1.065 * 0.733 * 235 = 1376.6 \text{ kN} < \phi V_c \quad \text{oK}$$

## B

$$b_o = 2(633) + 965 = 2231 \text{ mm}$$

$$\phi V_c = \phi \frac{\sqrt{f_c'}}{3} b_o d = 0.75 \times \frac{\sqrt{25}}{3} \times 665 \times 2231 / 1000 = 1854.5 \text{ kN}$$

$$\phi V_c = \phi \left( 2 + \frac{\alpha_s d}{b} \right) \frac{\sqrt{f_c'}}{12} b_o d = 0.75 \left( 2 + \frac{30 \times 665}{2231} \right) \times \frac{\sqrt{25}}{12} \times 665 \times 2231 / 1000 = 5273 \text{ kN}$$

$$V_u = 800(1.3) - 0.965 * 0.633 * 235 = 896.5 \text{ kN} < \phi V_c \quad \text{oK}$$



# Draw S.F.D & B.M.D

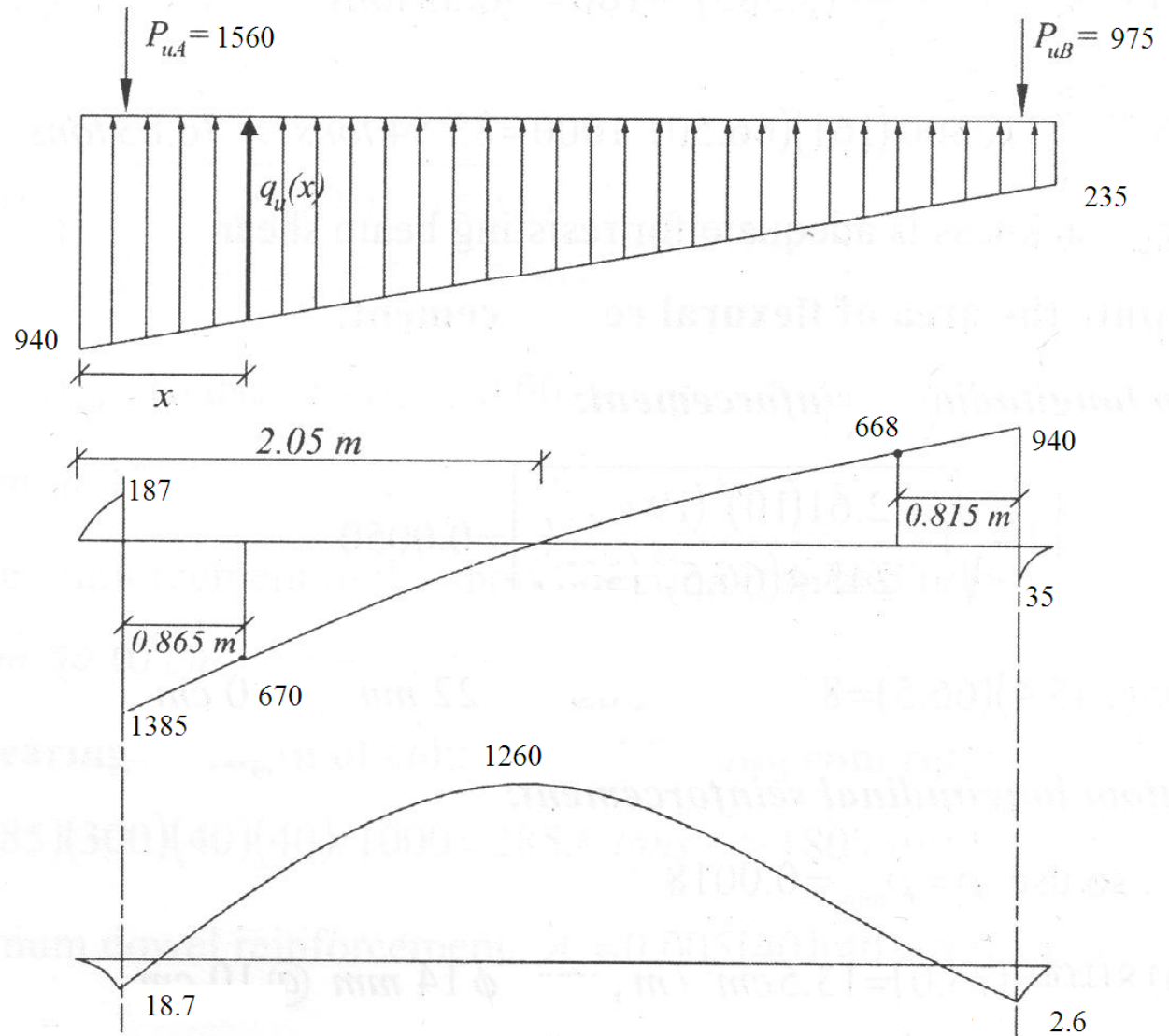

## Empirical S.F.D & B.M.D

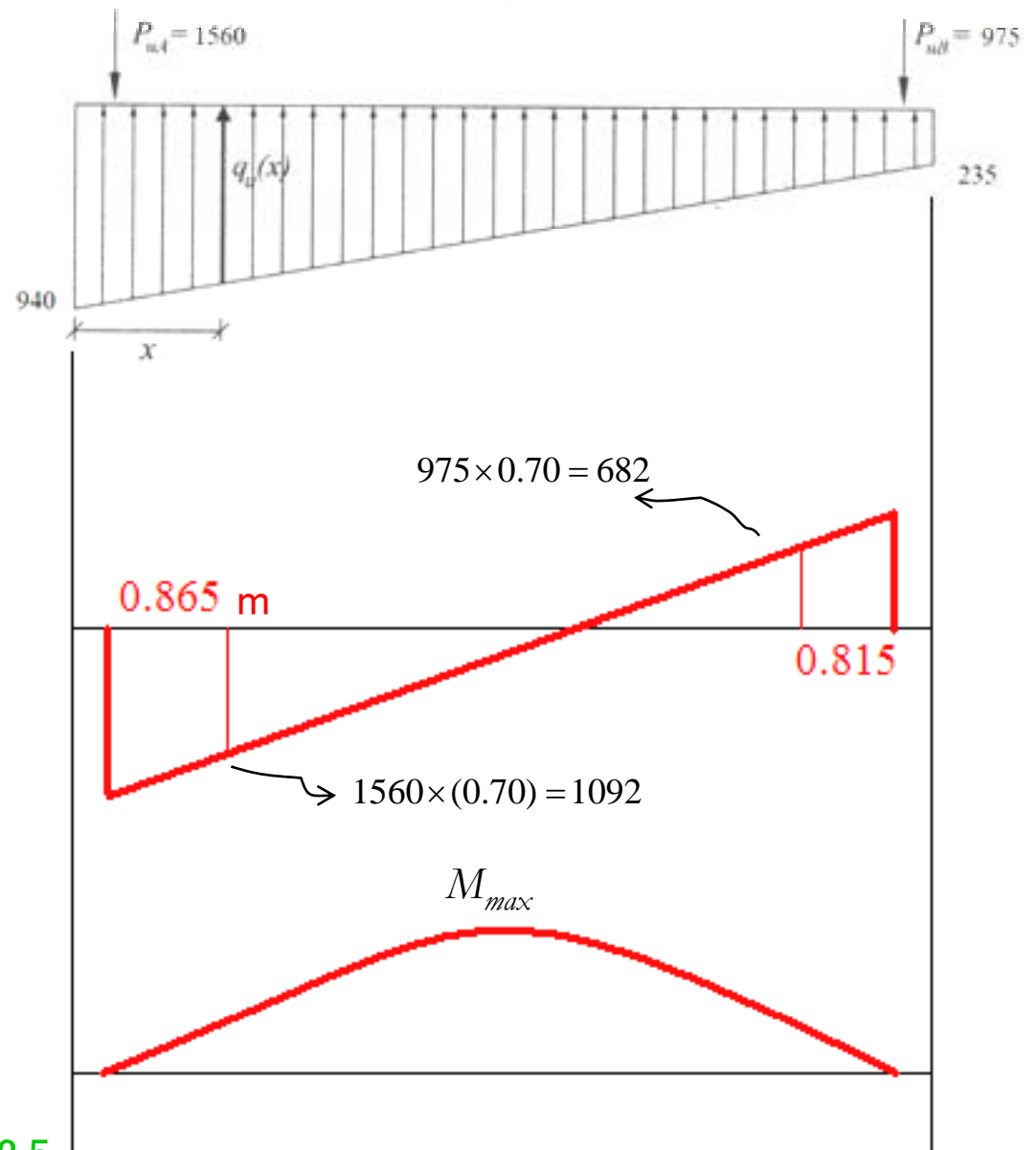

Convert trapezoidal load to rectangle

$$w_{ave} = 235 + \frac{2}{3}(940 - 235) = 705$$

$$-M_{max} = \frac{wl^2}{8} = \frac{705(3.65)^2}{8} = 1174 \text{ kN.m}$$

Clear distance between column

B in moment design = ave. width = 2.5m

## Check for beam shear

$$d = 665\text{mm}$$

$$b = 1 + 2\left(\frac{x}{L}\right) \times y$$

$$\text{at } x = 0.815 + 0.15$$

$$1 + 2\left(\frac{0.965}{4.35}\right) \times 1.5 = 1.7\text{m} = 1700\text{mm}$$

$$\phi V_C = 0.75 \times \frac{\sqrt{25}}{6} \times 665 \times 1700 / 1000 = 696\text{kN}$$

Max.  $\rightarrow V_U$  at d from column B face ( the most critical) = 668kN

$$V_U < \phi V_C$$

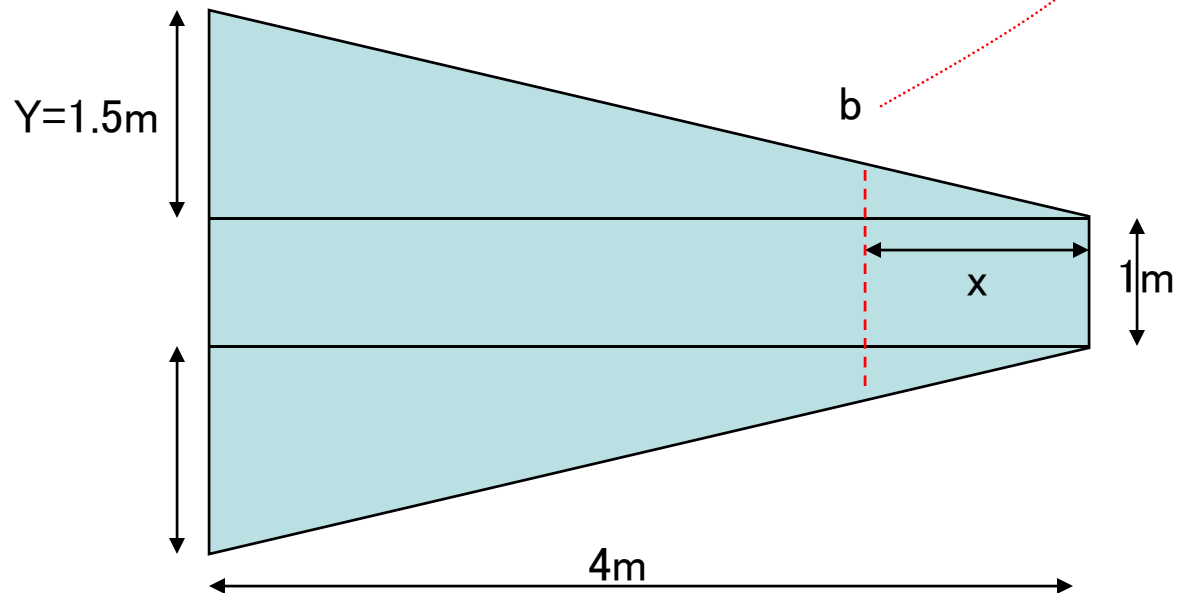

## Bending moment **Long direction**

*Top*

$$b = 1 + 2\left(\frac{2.25}{4.35}\right) \times 1.5 = 2.60m = 2600$$

$$-ve M = 1260kN.m$$

$$d = 730mm$$

$$\rho = 0.85 * \frac{25}{420} \left[ 1 - \sqrt{1 - \frac{2 \times 10^6 * 1260}{0.9(0.85)25 * 665^2 * 2600}} \right] = 0.003$$

$$A_s = 0.003 \times 665 \times 1000 = 1995mm^2 = 20cm^2 \quad use 10\phi 16 / m \quad Top$$

*Bottom*

$$A_{s\min} = 0.0018 \times 750 \times 1000 = 1350mm^2 = 13.5cm^2 \quad use 9\phi 14 / m \quad Bottom$$

# Bending moment **Short direction**

Under Column A

$$b' = 1 + 2\left(\frac{3.62}{4.35}\right) \times 1.5 = 3.5m = 3500mm$$

$$b' = 1 + 2\left(\frac{0.633}{4.35}\right) \times 1.5 = 1.44m = 1440mm$$

$$b = \frac{3.5 + 4}{2} m = 3.75m = 3750mm$$

$$M = \frac{1560}{(3.75 * 0.733)} \times \frac{0.733}{2} \left(\frac{3.75 - 0.4}{2}\right)^2 = 583.6$$

$$d = 665mm$$

$$\rho = 0.85 * \frac{25}{420} \left[ 1 - \sqrt{1 - \frac{2 \times 10^6 * 583.57}{0.9(0.85)25 * 665^2 * 733}} \right] = 0.005$$

$$A_s = 0.005 \times 665 \times 733 = 3325mm^2 = 33cm^2 \quad \text{use } 10\phi 20$$

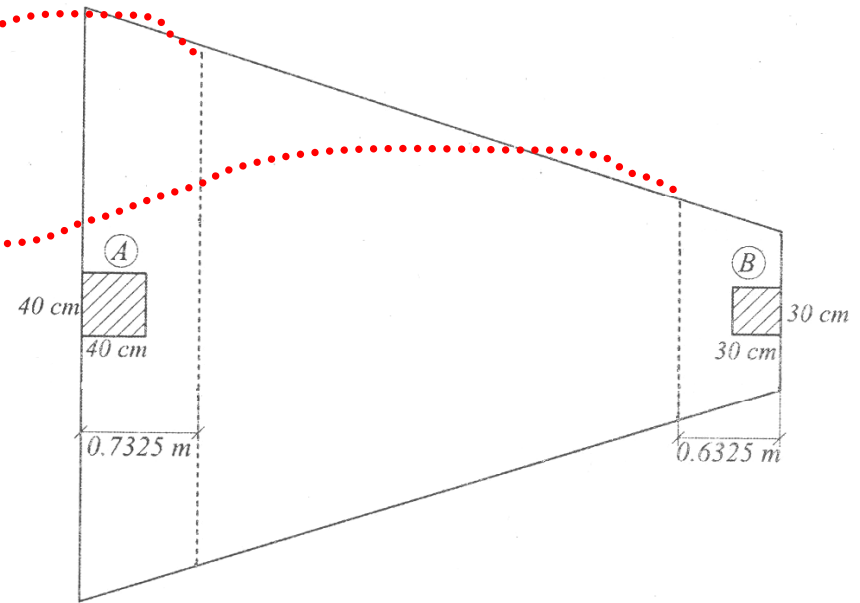

## Under Column B

$$b = \frac{1.44+1}{2} m = 1.22m = 1220mm$$

$$M = \frac{975}{(1.22 * 0.633)} \times \frac{0.633}{2} \left( \frac{1.22 - 0.3}{2} \right)^2 = 84.6$$

$$b = 633mm, d = 665mm$$

$$\rho = 0.85 * \frac{25}{420} \left[ 1 - \sqrt{1 - \frac{2 \times 10^6 * 84.6}{0.9(0.85)25 * 665^2 * 633}} \right] < \rho_{\min}$$

$$A_{S\min} = 0.0018 \times 750 \times 633 = 854.6mm^2 = 8.6cm^2 \quad \text{use } 6\phi 14$$

## Shrinkage Reinforcement in short direction

$$A_{S\min} = 0.0018 \times 1000 \times 750 = 1350mm^2 = 13.5cm^2 \quad \text{use } 9\phi 14 / m$$

## Reinforcement details

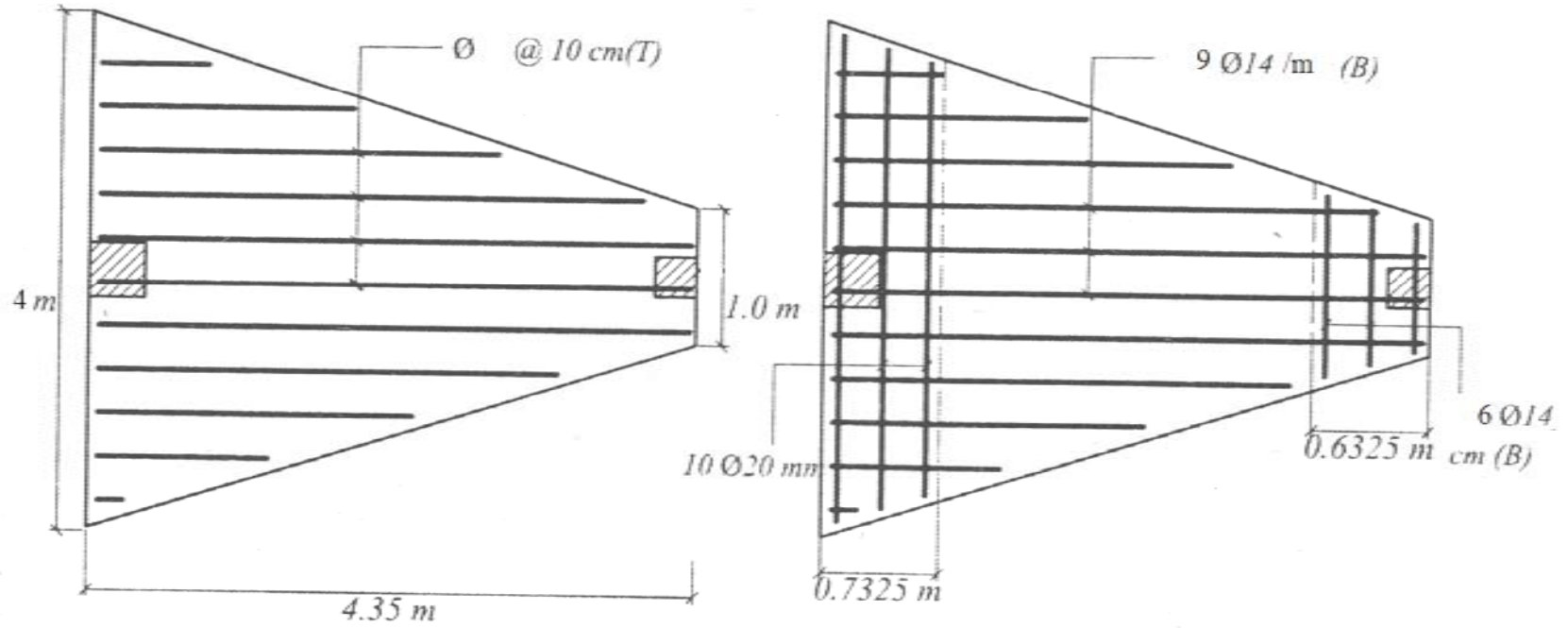

# Example 3 (Strip footing)

Design a combined footing As shown

$$q_{all(net)} = 20t / m^2 = 200kPa \quad f'_c = 25 N/mm^2 \quad f_y = 420 N/mm^2$$

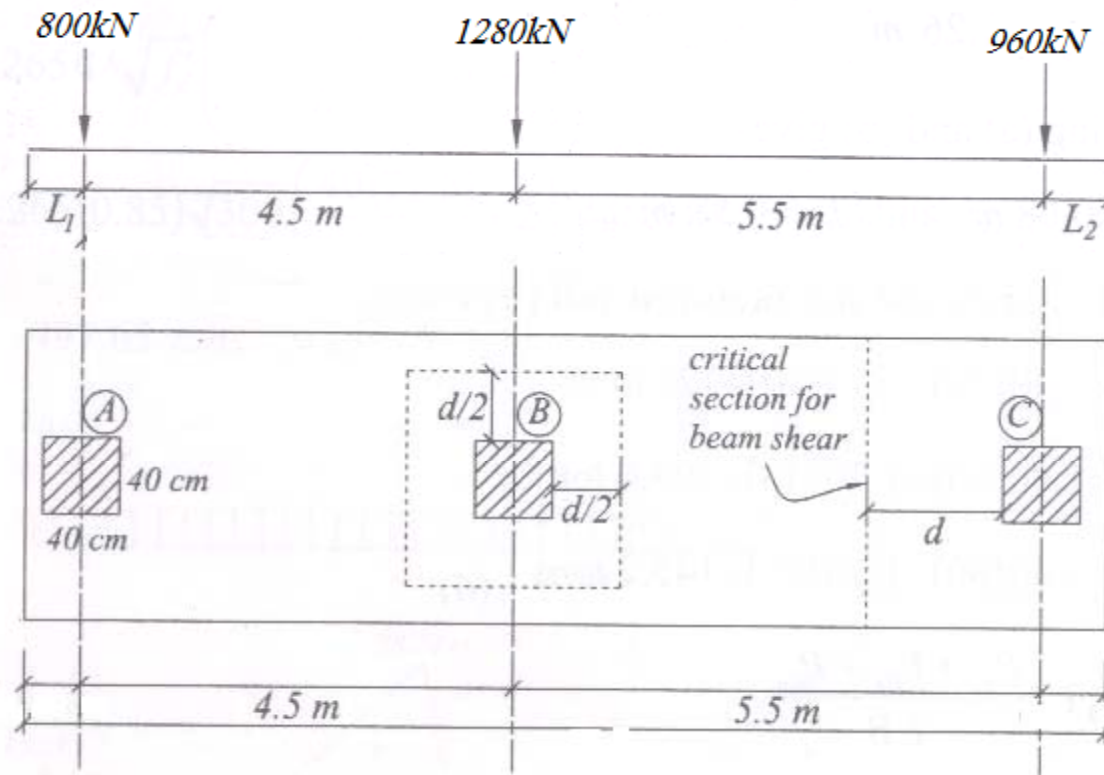



## Dimension calculation

The base dimension to get uniform distributed load

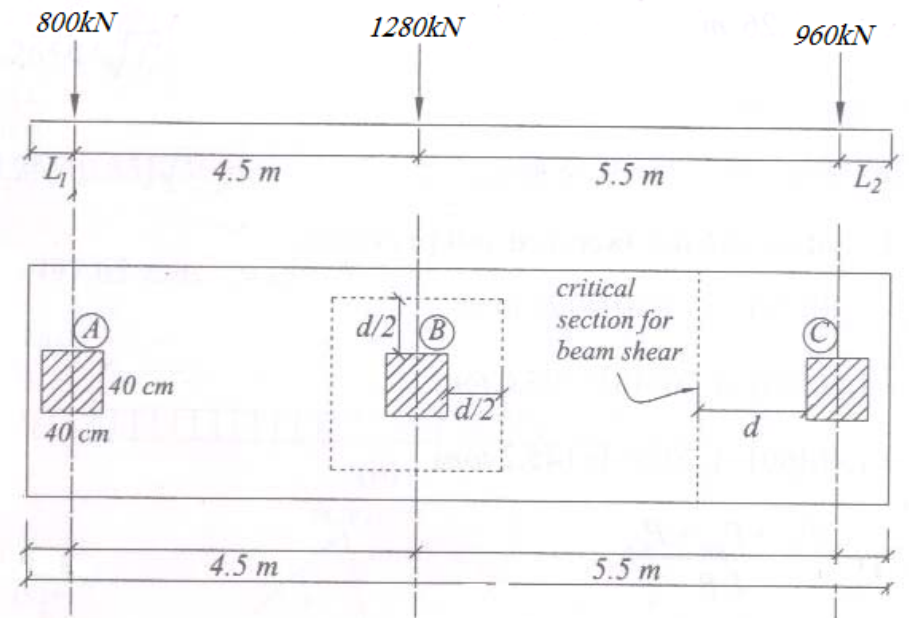
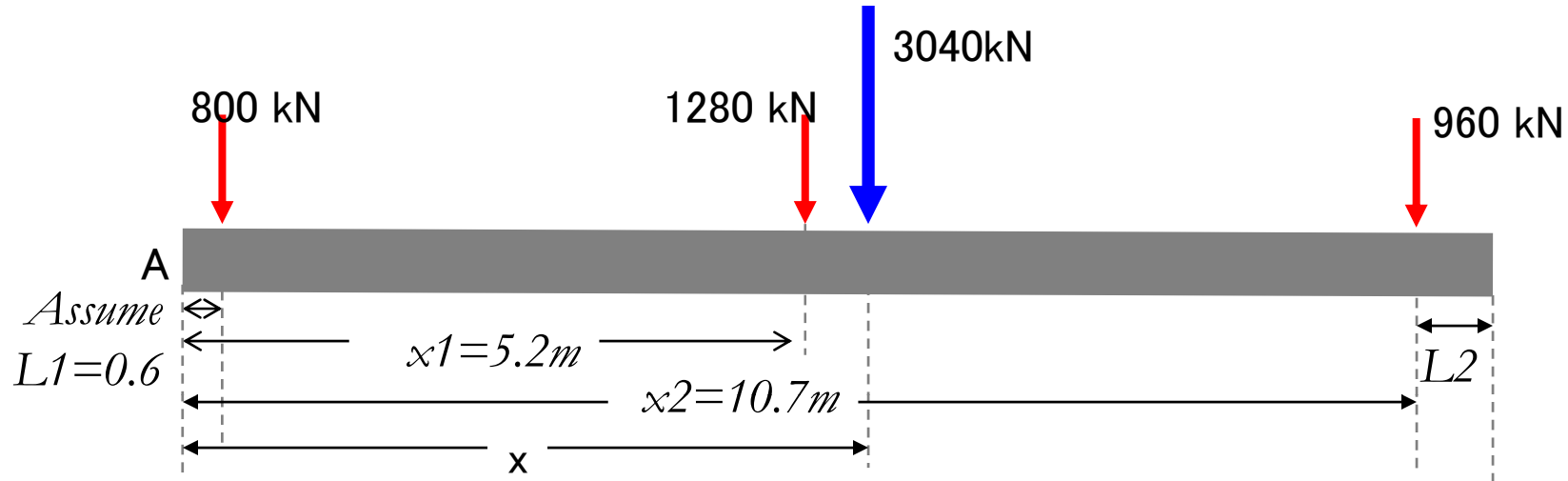

$$800(0.6) + 1280(5.1) + 960(10.6) =$$

$$3040 (x)$$

$$x = 5.65m,$$

$$2(x) = 11.3m$$

$$L_2 = 11.3 - (10.6) = 0.7$$

$$q_{all(net)} = 18t / m^2 = 180kPa,$$

$$A_g = \frac{P_s}{q_{all(net)}} = \frac{3040 \times 10^3}{180 \times 10^3} = 16.9m^2 \approx 11.3m \times 1.8m$$

$$q_u = \frac{P_u}{A} = \frac{1.3(3040) \times 10^3}{11.3 \times 1.8} = 195 \times 10^3 Pa = 195kPa$$

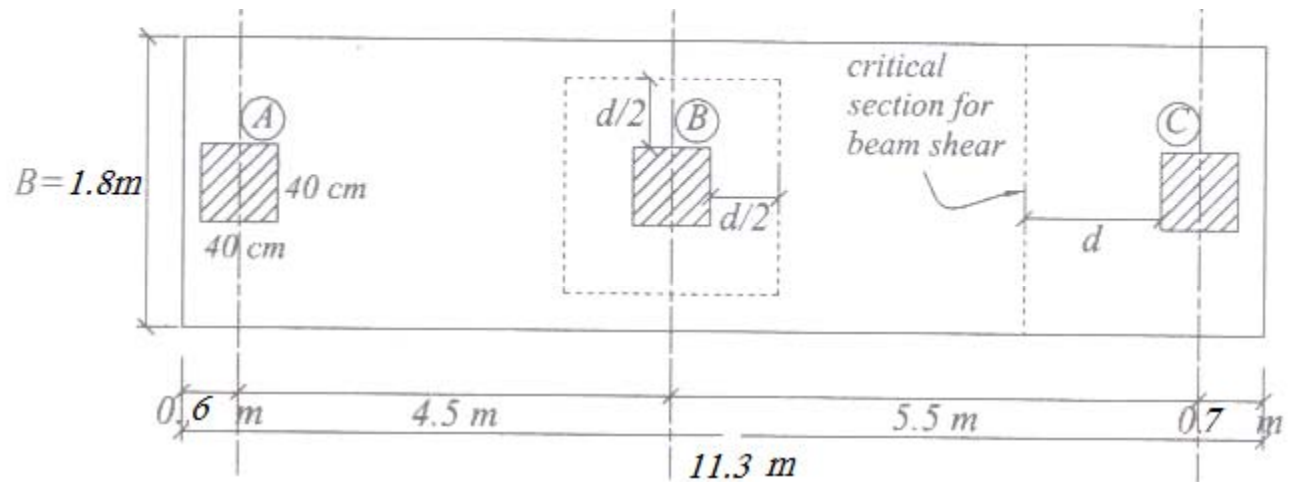

## Check for punching Shear

$$h = 700 \text{ mm}$$

$$d = 630 \text{ mm}$$

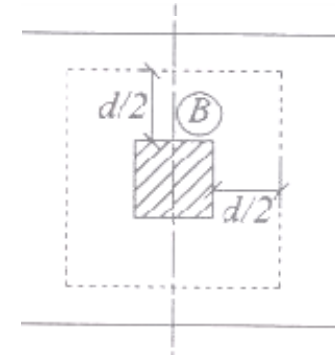

Example

**B**

$$b_o = 4(630 + 400) = 4120 \text{ mm}$$

$$\phi V_c = \phi \frac{\sqrt{f_c'}}{3} b_o d = 0.75 \times \frac{\sqrt{25}}{3} \times 630 \times 4120 / 1000 = 3244.5 \text{ kN}$$

$$\phi V_c = \phi \left( 2 + \frac{\alpha_s d}{b} \right) \frac{\sqrt{f_c'}}{12} b_o d = 0.75 \left( 2 + \frac{40 \times 630}{4120} \right) \times \frac{\sqrt{25}}{12} \times 630 \times 4120 / 1000 = 6584 \text{ kN}$$

$$V_U = 1280(1.3) - 1.03^2 * 195 = 1457.1 \text{ kN} < \phi V_c \quad \text{oK}$$

You can check other columns

# Draw S.F.D & B.M.D

*Stress under footing*  
 $= 195 * 1.8 = 351 \text{ kN/m}$

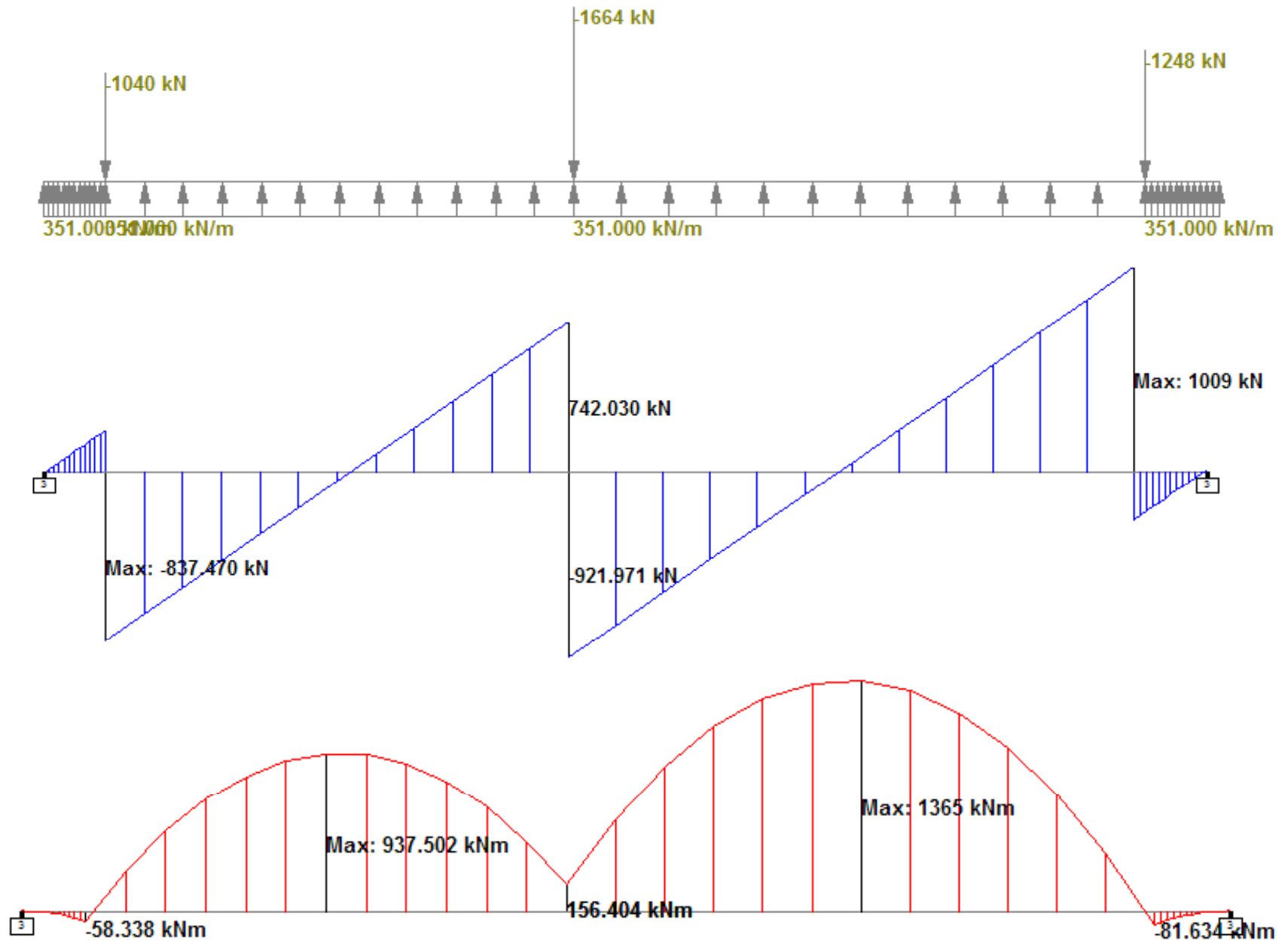

## Check for beam shear

$$b = 1800\text{mm}, d = 630\text{mm}$$

$$\phi V_C = 0.75 \times \frac{\sqrt{25}}{6} \times 630 \times 1800 / 1000 = 708.75\text{kN}$$

$$\text{Max.} \rightarrow V_U \text{ at } \underline{\underline{d}} \text{ from column face} \approx 0.7(1009) = 706.3\text{kN}$$

$$V_U < \phi V_C$$

## Bending moment Long direction

$$-ve M = 1366kN.m$$

$$b = 1800mm, d = 730mm$$

$$\rho = 0.85 * \frac{25}{420} \left[ 1 - \sqrt{1 - \frac{2 \times 10^6 * 1365}{0.9(0.85)25 * 630^2 * 1800}} \right] = 0.0053$$

$$A_s = 0.0053 \times 630 \times 1000 = 3362mm^2 = 33.6cm^2 \quad use 9\phi22 / m \quad \text{Top}$$

$$+ve M = 246.7kN.m$$

$$b = 1800mm, d = 730mm$$

$$\rho = 0.85 * \frac{25}{420} \left[ 1 - \sqrt{1 - \frac{2 \times 10^6 * 81}{0.9(0.85)25 * 730^2 * 1800}} \right] < \rho_{min}$$

$$A_{s_{min}} = 0.0018 \times 700 \times 1000 = 1260mm^2 = 12.6cm^2 \quad use 8\phi14 / m \quad \text{Bottom}$$

**Design Short direction as example 1 (lecture 11)**

Reinforcement details

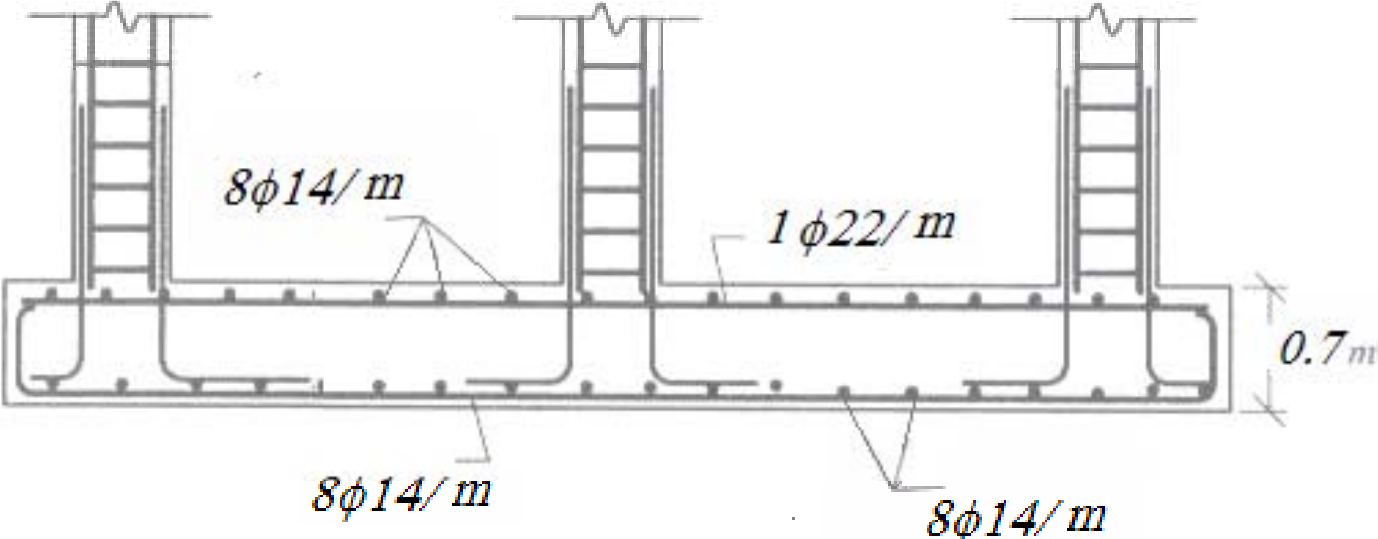

# Mat Foundation

$$q = \frac{\sum P}{A} \pm \frac{M_x y}{I_x} \pm \frac{M_y x}{I_y}$$

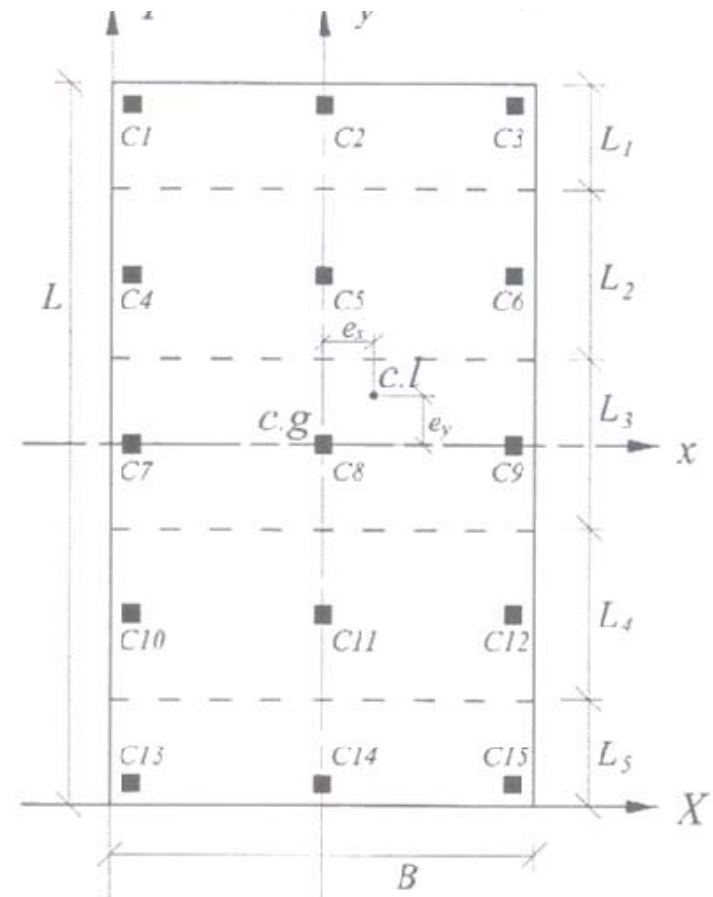
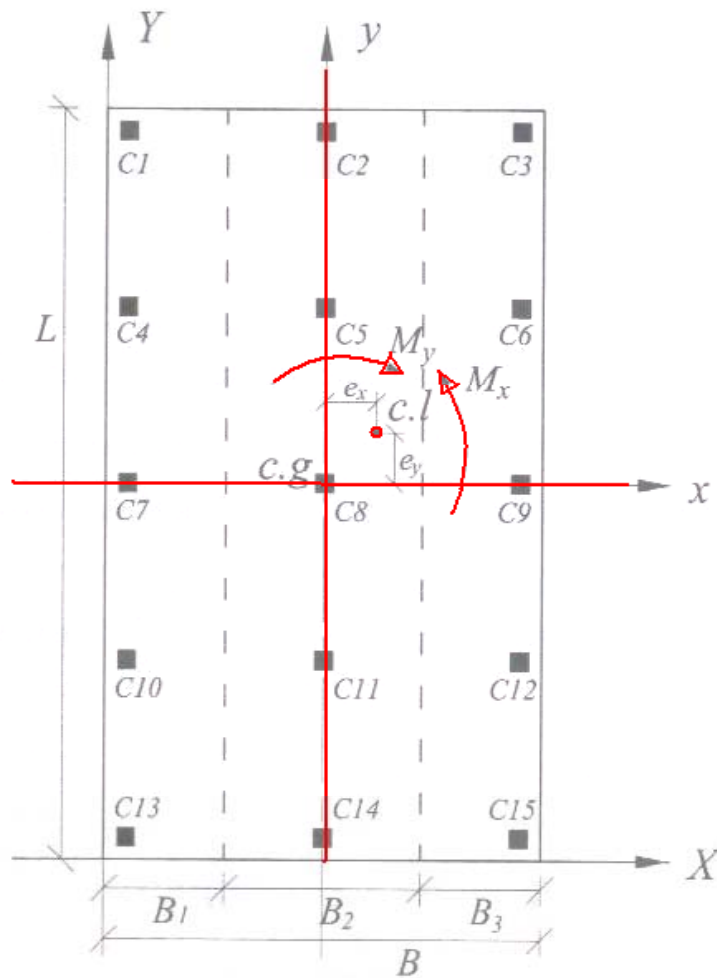
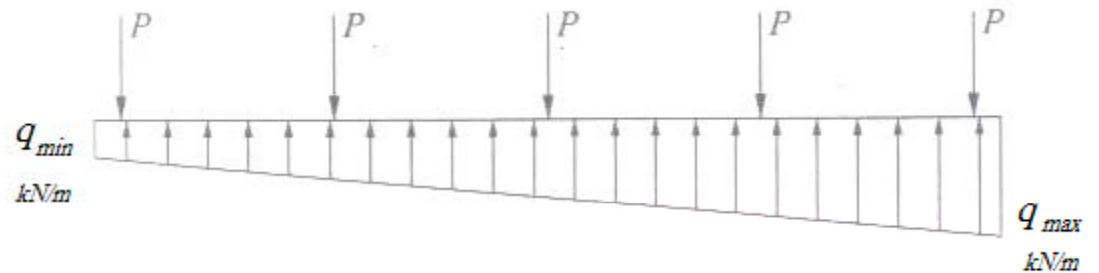



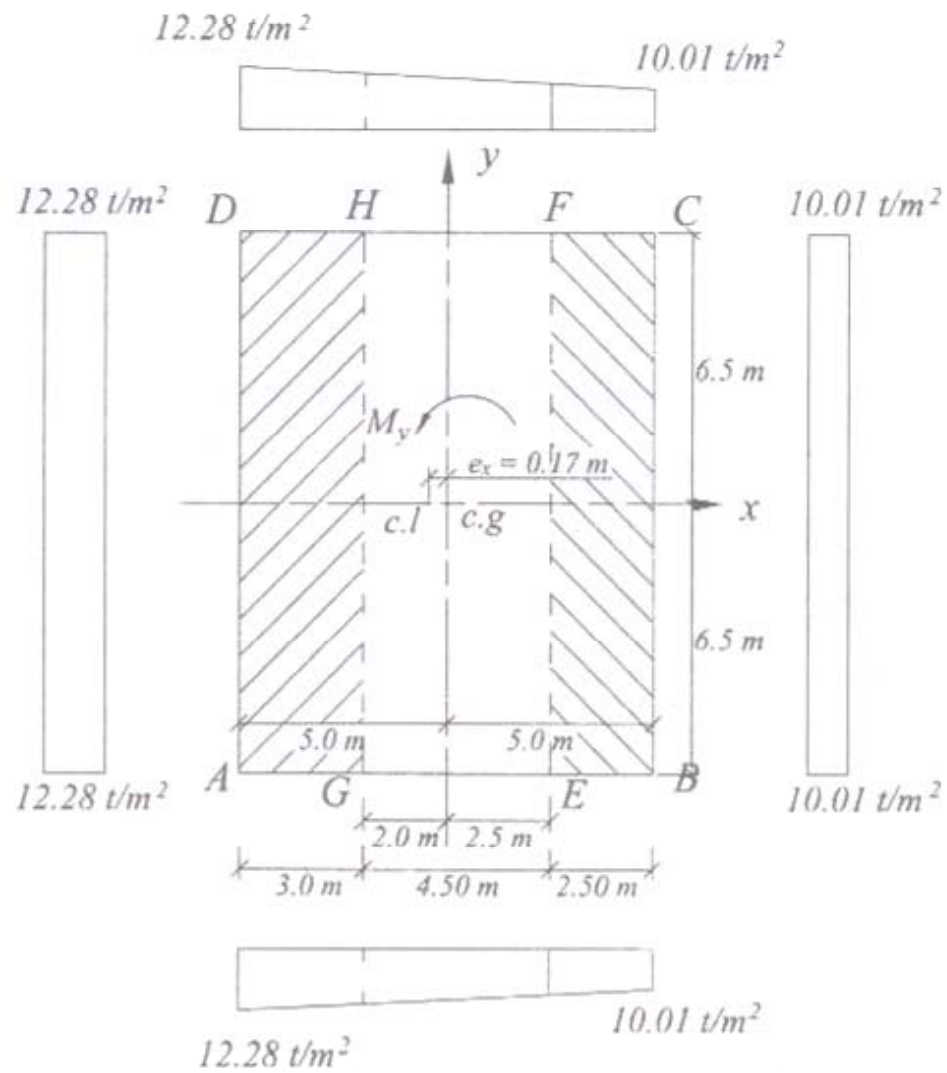

# Check for punching Shear

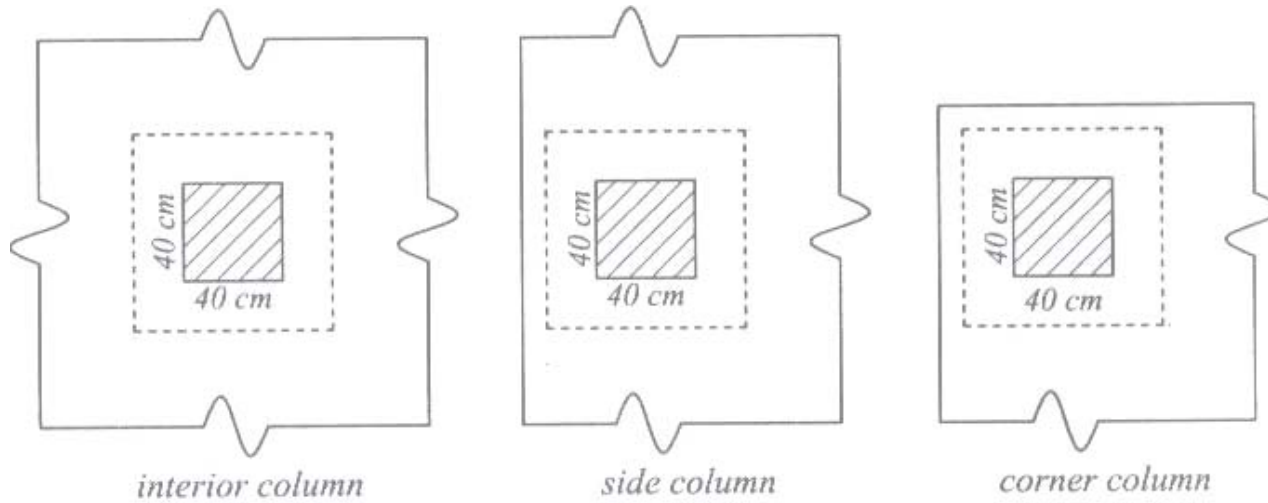

# General Example, <sup>Ref. 2</sup>

Modified load

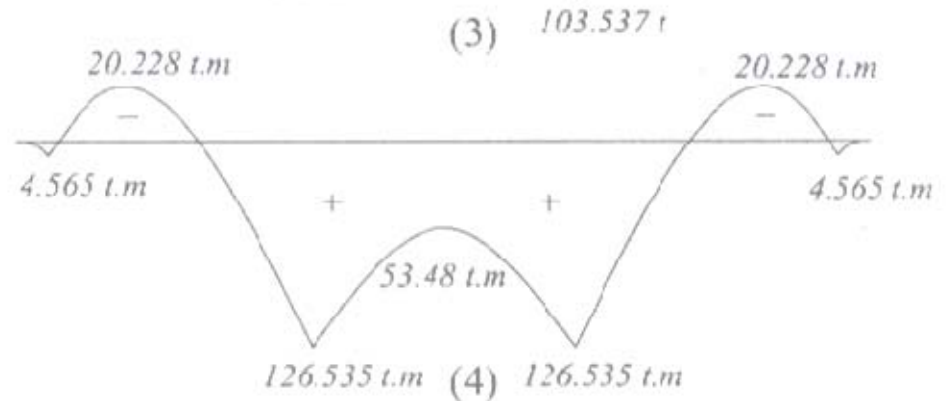
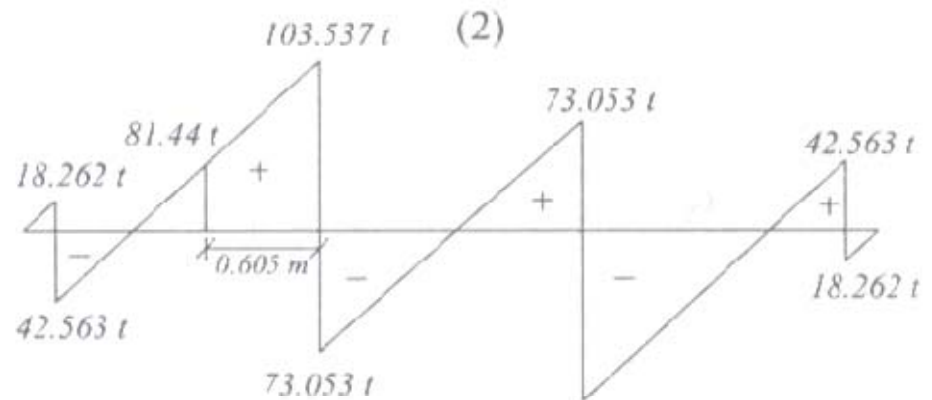
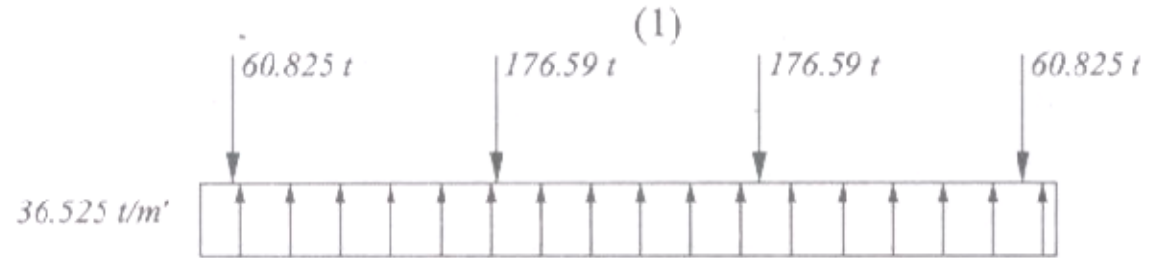
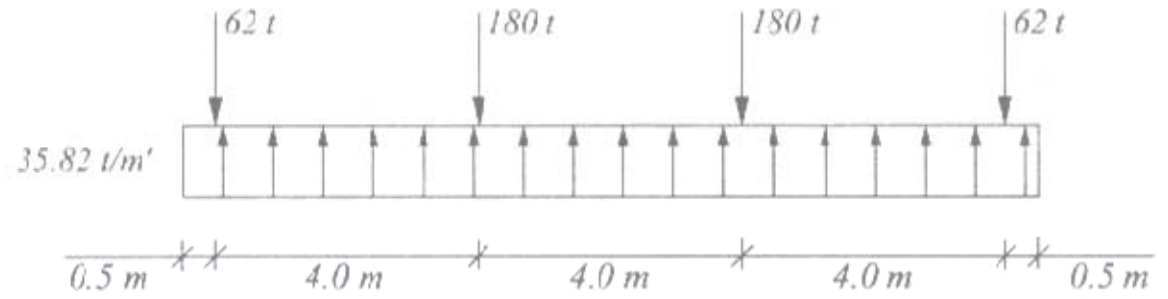

## General reinforcement details

